

- **768 × 1 Sensor-Element Organization**
- **400 Dot-Per-Inch (DPI) Sensor Pitch**
- **High Linearity and Low Noise for 256 Gray-Scale Applications**
- **Output Referenced to Ground**
- **Low Image Lag . . . 0.5% Typ**
- **Operation to 2 MHz**
- **Single 5-V Supply**

Description

The TSL1406 is a 400 dots-per-inch (DPI) linear sensor array consisting of two 384-pixel sections, each with its own output. The sections are aligned to form a contiguous 768 × 1 pixel array. The device incorporates a pixel data-hold function that provides simultaneous integration-start and integration-stop times for all pixels. The pixels measure 63.5 μm by 55.5 μm, with 63.5-μm center-to-center spacing and 8-μm spacing between pixels. Operation is simplified by internal logic that requires only a serial-input (SI) pulse and a clock.

The device operates from a single 5-V power source. The two sections of 384 pixels each can be read out separately or can be cascaded to provide a single output for all 768 pixels (see Figure 3).

The TSL1406 is intended for use in a wide variety of applications including mark and code reading, OCR and contact imaging, edge detection and positioning, and optical encoding.

Functional Block Diagram (each section)

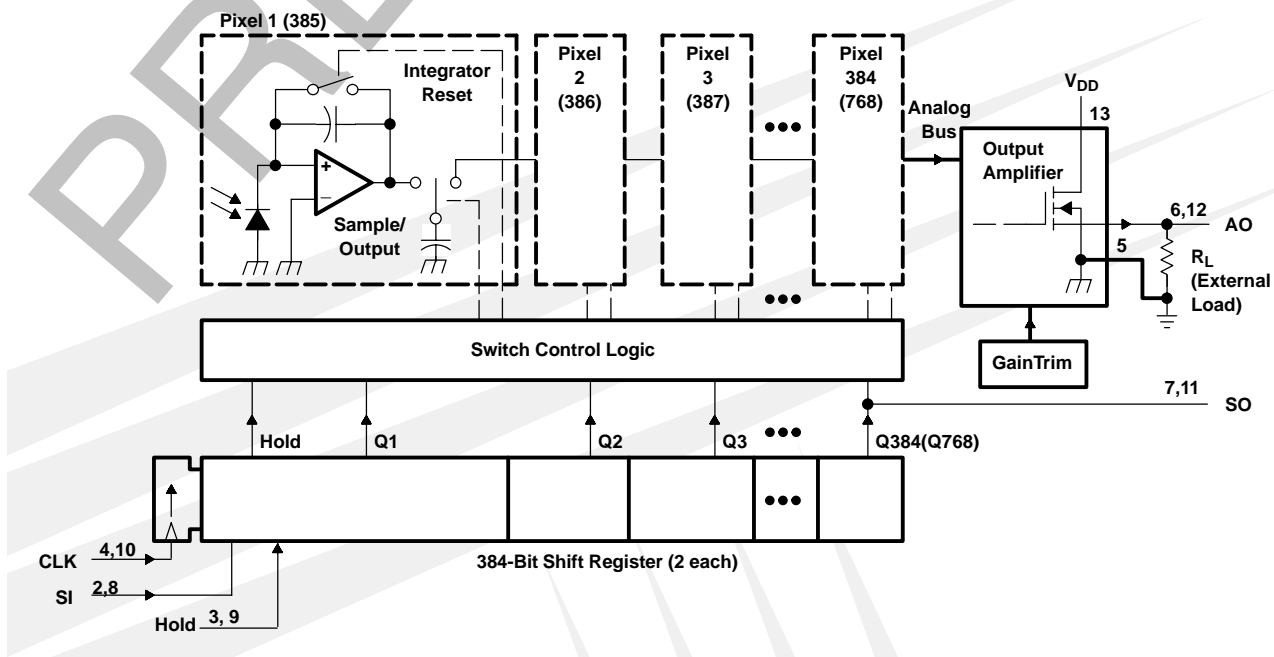

TSL1406

768 × 1 LINEAR SENSOR ARRAY WITH HOLD

TAOS013 – SEPTEMBER 1999

Terminal Functions

TERMINAL NAME	NO.	I/O	DESCRIPTION
AO1	6	O	Analog output, section 1.
AO2	12	O	Analog output, section 2.
CLK1	4	I	Clock, section 1. CLK1 controls charge transfer, pixel output, and reset.
CLK2	10	I	Clock, section 2. CLK2 controls charge transfer, pixel output, and reset.
GND	5		Ground (substrate). All voltages are referenced to GND.
HOLD1	3	I	Hold signal. HOLD1 shifts pixel data to parallel buffer. HOLD1 is normally connected to SI1.
HOLD2	9	I	Hold signal. HOLD2 shifts pixel data to parallel buffer. HOLD2 is normally connected to SI2.
SI1	2	I	Serial input (section 1). SI1 defines the start of the data-out sequence.
SI2	8	I	Serial input (section 2). SI2 defines the start of the data-out sequence.
SO1	7	O	Serial output (section 1). SO1 provides a signal to drive the SI2 input.
SO2	11	O	Serial output (section 2). SO2 provides a signal to drive the SI input of another device for cascading or as an end-of-data indication.
V _{DD}	13		Supply voltage for both analog and digital circuitry
V _{pp}	1		Normally grounded

Detailed Description

The sensor consists of 768 photodiodes, called pixels, arranged in a linear array. Light energy impinging on a pixel generates photocurrent that is then integrated by the active integration circuitry associated with that pixel.

During the integration period, a sampling capacitor connects to the output of the integrator through an analog switch. The amount of charge accumulated at each pixel is directly proportional to the light intensity on that pixel and the integration time.

The output and reset of the integrators are controlled by a 384-bit shift register and reset logic. An output cycle is initiated by clocking in a logic 1 on SI. Another signal, called HOLD, is generated from the rising edge of SI1 when SI1 and HOLD1 are connected together. This causes all 384 sampling capacitors to be disconnected from their respective integrators and starts an integrator reset period. As the SI pulse is clocked through the shift register, the charge stored on the sampling capacitors is sequentially connected to a charge-coupled output amplifier that generates a voltage on analog output AO. The integrator reset period ends 18 clock cycles after the SI pulse is clocked in. Then the next integration period begins. On the 384th clock rising edge, the SI pulse is clocked out on the SO1 pin (section 1) and becomes the SI pulse for section 2 (when SO1 is connected to SI2). The rising edge of the 385th clock cycle terminates the SO1 pulse, and returns the analog output AO of section 1 to high-impedance state. Similarly, SO2 is clocked out on the 768th clock pulse. Note that a 769th clock pulse is needed to terminate the SO2 pulse and return AO of Section 2 to the high-impedance state. Sections 1 and 2 may be operated in parallel or in serial fashion.

AO is driven by a source follower that requires an external pulldown resistor. When the output is not in the output phase, it is in a high-impedance state. The output is nominally 0 V for no light input and 2 V for a nominal full-scale output.

Absolute Maximum Ratings over operating free-air temperature range (unless otherwise noted)†

Supply voltage, V_{DD}	7 V
Digital output current range, V_O	0.5 V to V_{DD} 0.5 V
Digital output current	-10 mA to 10 mA
Digital input current range, I_I	-20 mA to 20 mA
Operating free-air temperature range, T_A	0°C to 70°C
Storage temperature range, T_{stg}	-25°C to 85°C
Lead temperature 1,6 mm (1/16 inch) from case for 10 seconds	260°C

† Stresses beyond those listed under “absolute maximum ratings” may cause permanent damage to the device. These are stress ratings only, and functional operation of the device at these or any other conditions beyond those indicated under “recommended operating conditions” is not implied. Exposure to absolute-maximum-rated conditions for extended periods may affect device reliability.

Recommended Operating Conditions

		MIN	NOM	MAX	UNIT
Supply voltage, V_{DD}		4.5	5	5.5	V
Input voltage, V_I		0		V_{DD}	V
High-level input voltage, V_{IH}		$V_{DD} \times 0.7$		V_{DD}	V
Low-level input voltage, V_{IL}		0		$V_{DD} \times 0.3$	V
Wavelength of light source, λ		400		1100	nm
Clock frequency, f_{clock}		5		2000	kHz
Sensor integration time, t_{int}	Serial connection	0.384	5	10	ms
	Parallel connection	0.192	5	10	
Setup time, serial input, $t_{su(SI)}$		20			ns
Hold time, serial input, $t_h(SI)$ (see Note 1)		0			ns
Operating free-air temperature, T_A		0		70	°C

NOTE 1: SI must go low before the rising edge of the next clock pulse.

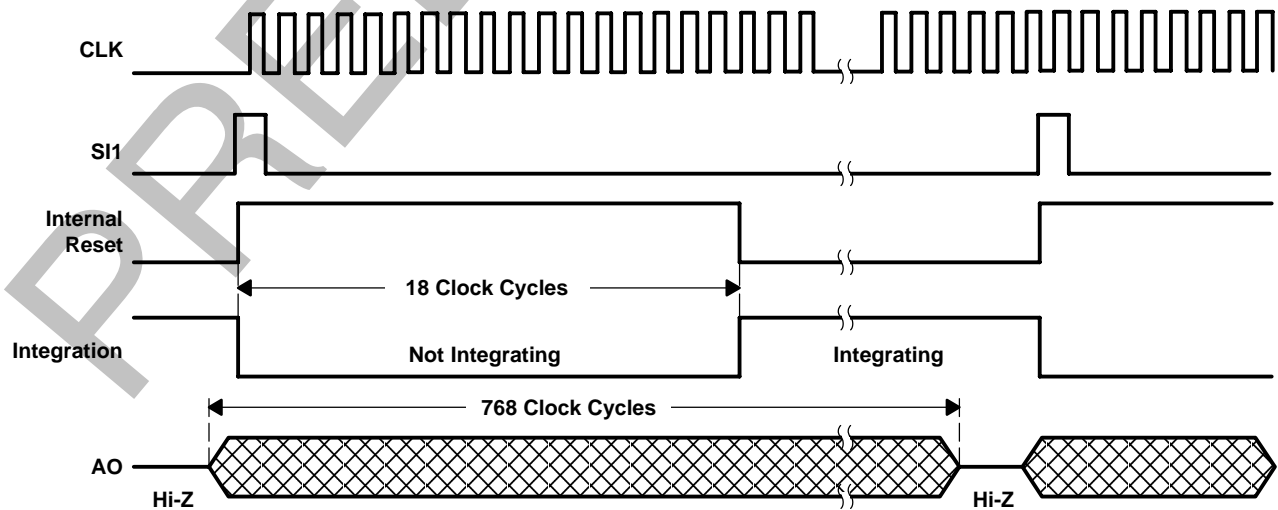

Figure 1. Timing Waveforms (serial connection)

TSL1406

768 × 1 LINEAR SENSOR ARRAY WITH HOLD

TAOS013 – SEPTEMBER 1999

Electrical Characteristics at $f_{\text{clock}} = 200 \text{ kHz}$, $V_{\text{DD}} = 5 \text{ V}$, $T_{\text{A}} = 25^{\circ}\text{C}$, $\lambda_{\text{p}} = 660 \text{ nm}$, $t_{\text{int}} = 5 \text{ ms}$, $R_{\text{L}} = 330 \Omega$, $E_{\text{e}} = 20 \mu\text{W}/\text{cm}^2$ (unless otherwise noted) (see Note 2)

PARAMETER		TEST CONDITIONS	MIN	TYP	MAX	UNIT
	Analog output voltage (white, average over 256 pixels)		1.8	2	2.2	V
	Analog output voltage (dark, average over 256 pixels)	$E_{\text{e}} = 0$	0	0.1	0.3	V
PRNU	Pixel response nonuniformity	See Note 3			±15%	
	Nonlinearity of analog output voltage	See Note 4		0.4%		FS
	Output noise voltage	$E_{\text{e}} = 0$, See Note 5		1		mVrms
	Saturation exposure	$V_{\text{DD}} = 4.5 \text{ V}$, See Note 6	136	150		nJ/cm ²
	Analog output saturation voltage	$V_{\text{DD}} = 4.5 \text{ V}$	3	3.5		V
DSNU	Dark signal nonuniformity	All pixels, $E_{\text{e}} = 0$, See Note 7		0.05	0.15	V
IL	Image lag	See Note 8		0.5%		
I_{DD}	Supply current	$R_{\text{L}} = 330 \Omega$		25	45	mA
I_{IH}	High-level input current	$V_{\text{I}} = V_{\text{DD}}$			10	μA
I_{IL}	Low-level input current	$V_{\text{I}} = 0$			10	μA
C_{i}	Input capacitance			10		pF

- NOTES:
- Clock duty cycle is assumed to be 50%.
 - PRNU is the maximum difference between the voltage from any single pixel and the average output voltage from all pixels of the device under test when the array is uniformly illuminated.
 - Nonlinearity is defined as the maximum deviation from a best-fit straight line over the dark-to-white irradiance levels, as a percent of analog output voltage (white).
 - RMS noise is the standard deviation of a single-pixel output under constant illumination as observed over a 5-second period.
 - Minimum saturation exposure is calculated using the maximum responsivity and minimum output saturation voltage figures.
 - DSNU is the difference between the maximum and minimum of dark-current voltage.
 - Image lag is a residual signal left in a pixel from a previous exposure. It is defined as a percent of white-level signal remaining after a pixel is exposed to a white condition followed by a dark condition:

$$IL = \frac{V_{\text{AO}} - V_{\text{AO(dark)}}}{V_{\text{AO(white)}} - V_{\text{AO(dark)}}} \times 100$$

Operating Characteristics over recommended ranges of supply voltage and operating free-air temperature (unless otherwise noted) (see Figure 2)

PARAMETER		TEST CONDITIONS	MIN	TYP	MAX	UNIT
$t_{pd(SO)}$	Propagation delay time, SO			50		ns
t_w	Pulse duration, clock high or low		50			ns
t_s	Analog output settling time to $\pm 1\%$	$R_L = 330 \Omega, C_L = 50 \text{ pF}$		350		ns

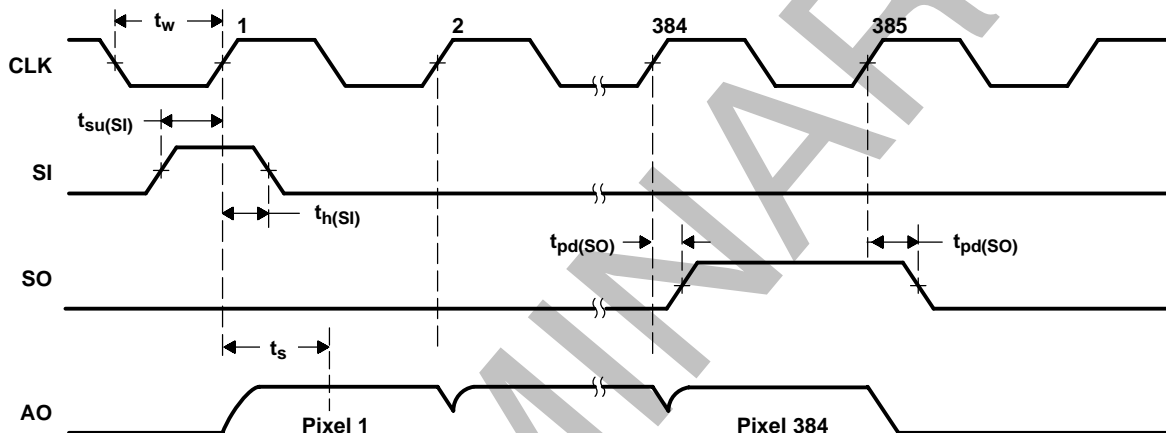

Figure 2. Operational Waveforms (each section)

TYPICAL CHARACTERISTICS

PHOTODIODE SPECTRAL RESPONSIVITY

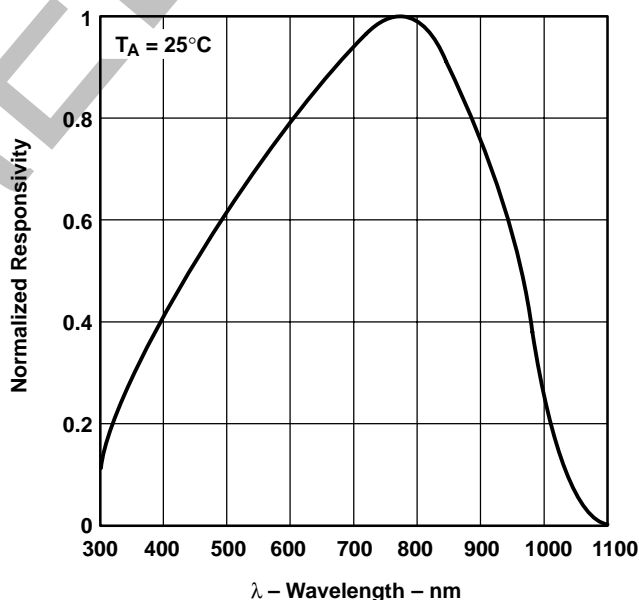

Figure 3

TSL1406
768 × 1 LINEAR SENSOR ARRAY WITH HOLD

TAOS013 – SEPTEMBER 1999

APPLICATION INFORMATION

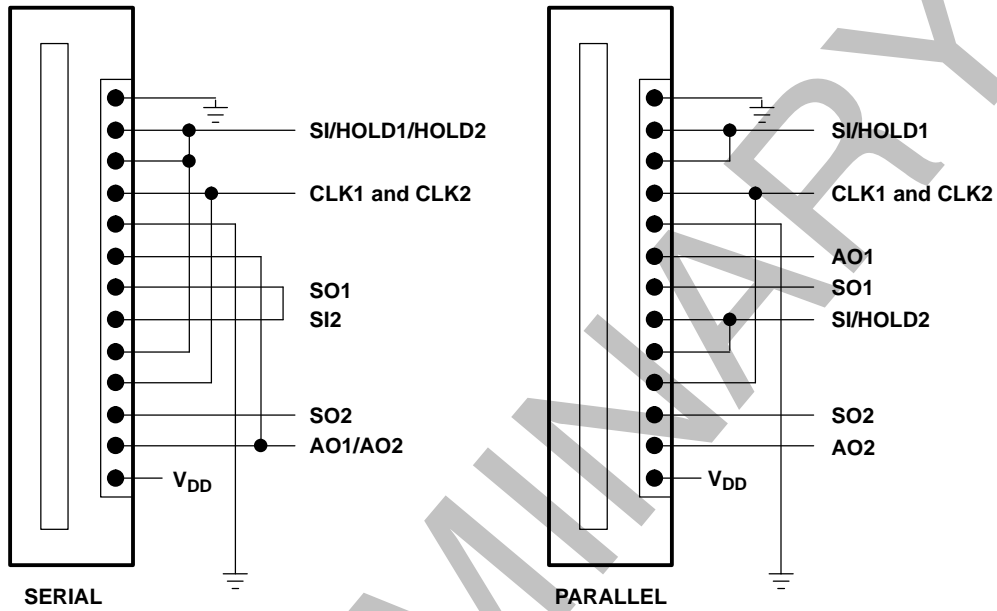
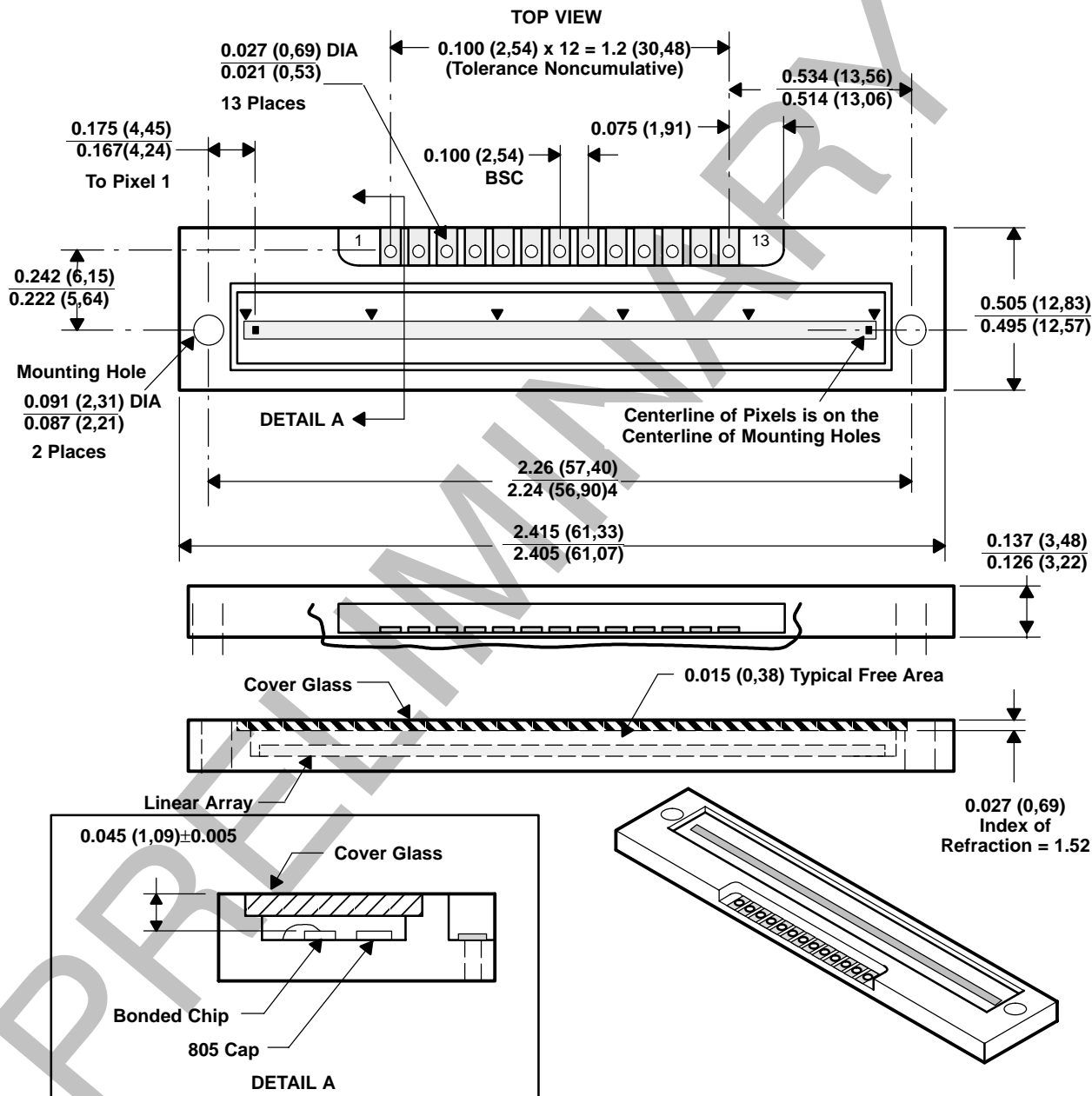

Figure 4. Operational Connections

PRELIMINARY

MECHANICAL DATA



- NOTES: A. All linear dimensions are in inches (millimeters).
B. This drawing is subject to change without notice.
C. Pixel centers are in line with center line of mounting holes.

Figure 5. TSL1406 Mechanical Specifications

TSL1406

768 × 1 LINEAR SENSOR ARRAY WITH HOLD

TAOS013 – SEPTEMBER 1999

PRELIMINARY DATA — information in this document is based on products in the preproduction phase of product development. Device characteristics and other specifications are subject to change without notice. Please contact Texas Advanced Optoelectronic Solutions, Inc. for the latest product documentation.

NOTICE

Texas Advanced Optoelectronic Solutions, Inc. (TAOS) reserves the right to make changes to the products contained in this document to improve performance or for any other purpose, or to discontinue them without notice. Customers are advised to contact TAOS to obtain the latest product information before placing orders or designing TAOS products into systems.

TAOS assumes no responsibility for the use of any products or circuits described in this document or customer product design, conveys no license, either expressed or implied, under any patent or other right, and makes no representation that the circuits are free of patent infringement. TAOS further makes no claim as to the suitability of its products for any particular purpose, nor does TAOS assume any liability arising out of the use of any product or circuit, and specifically disclaims any and all liability, including without limitation consequential or incidental damages.

TEXAS ADVANCED OPTOELECTRONIC SOLUTIONS, INC. PRODUCTS ARE NOT DESIGNED OR INTENDED FOR USE IN CRITICAL APPLICATIONS IN WHICH THE FAILURE OR MALFUNCTION OF THE TAOS PRODUCT MAY RESULT IN PERSONAL INJURY OR DEATH. USE OF TAOS PRODUCTS IN LIFE SUPPORT SYSTEMS IS EXPRESSLY UNAUTHORIZED AND ANY SUCH USE BY A CUSTOMER IS COMPLETELY AT THE CUSTOMER'S RISK.

PRELIMINARY