



For Surveillance Telephoto Zoom

Applicable camera (model)

1	2/3	1/2	1/3	1/4
---	-----	-----	-----	-----

22x



*Photograph is a similar model.

- Achieved telephoto at the field angle of 1°50', best suited for long-distance monitoring such as disaster prevention (when used on 1/2" cameras).
- With the amazing brightness of F1.2, reproducing excellent image quality over the entire visible light range.
- Multi power compatibility (6V, ±6V, 12V, ±12V), for use with existing control systems.
- Built-in potentiometer, supporting preset.
- Compatible with a wide range - 1/2", 1/3" and 1/4" - cameras.
- Built-in ND filter of T1500, supporting high sensitivity cameras.

ZOOM
Zoom

WIDE
Wide Angle

TELE
Telephoto Long Focal

MOTOR DRIVE
Motor Drive

VIDEO
Video Auto Iris

C-mt
C Mount

METAL
Metal Mount

PRESET
Potentiometer

ND
ND Filter

F1.2
Wide Aperture Rate

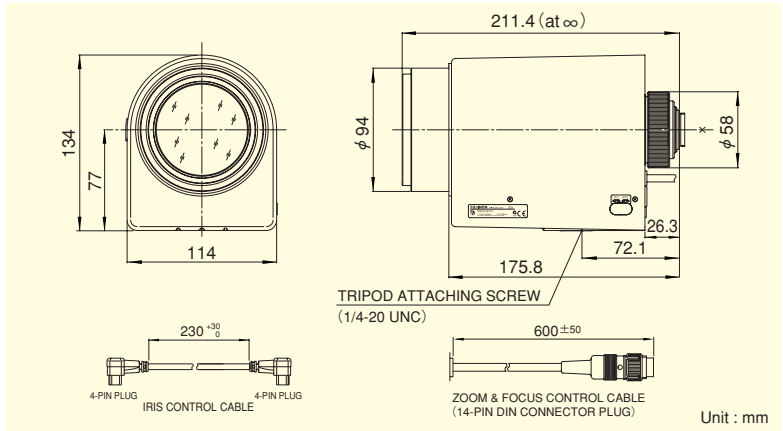

Unit : mm

Focal Length (mm)		9.1~200 (22x)	
Iris Range		F1.2 ~ T1500 (Equivalent to F1500)	
Operation	Zoom	Motor Drive	
	Focus	Motor Drive	
	Iris	Auto (Video Type)	
Angle Of View (H×V)	1/2"	WIDE	38°45' × 29°33'
		TELE	1°50' × 1°23'
	1/3"	WIDE	29°33' × 22°23'
		TELE	1°23' × 1°02'
	1/4"	WIDE	22°23' × 16°53'
		TELE	1°02' × 0°46'
Focusing Range (From Front Of The Lens) (m)		∞ ~ 3	
Object Dimensions at M.O.D. (H×V) (mm)	1/2"	WIDE	2034 × 1526
		TELE	93 × 69
	1/3"	WIDE	1526 × 1144
		TELE	69 × 52
	1/4"	WIDE	1144 × 858
		TELE	52 × 39
Back Focal Distance (in air) (mm)		23.93	
Exit Pupil Position (From Image Plane) (mm)		-676	
Filter Thread (mm)		M82 × 0.75	
Mount		C	
Mass (kg)		2.3	
Standard Accessories		Iris Control Cable Connection Connector (14-pin)	
Remarks		• With Metal Mount	

Wiring

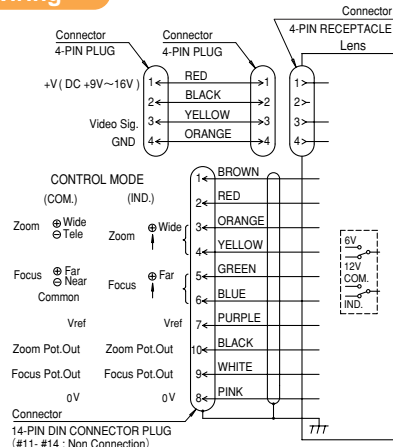

Control Mode

(Rear View)

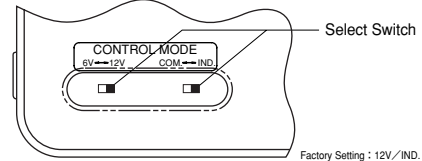

Controller output	Select switch position
6V	6V/IND.
±6V	6V/COM.
12V	12V/IND.
±12V	12V/COM.

Accessories

Extender

Model	Magnification
HE15-1	1.5X
HE20-1	2X