

5000 PIXELS CCD LINEAR IMAGE SENSOR

The μ PD3739 is a CCD (Charge Coupled Device) linear image sensor which changes optical images to electrical signal.

The μ PD3739 is a 2-output type CCD sensor with 2 rows of high-speed charge transfer register, which transfers the photo signal electrons of 5000 pixels separately in odd and even pixels. It is suitable for 400 dpi/A3 high-speed digital copiers, OCRs and high-end business facsimiles.

FEATURES

- Valid photocell : 5000 pixels
- Photocell's pitch : 7 μ m
- High sensitivity : 9.0 V/lx-s TYP. (Light source: Daylight color fluorescent lamp)
- Low image lag : 1 % MAX.
- Peak response wavelength : 550 nm (green)
- Resolution : 16 dot/mm (400 dpi) A3 (297 \times 420 mm) size (shorter side)
- Data rate : 40 MHz MAX. (20 MHz/1 output)
- Output type : 2 outputs out of phase (2 outputs in phase also supported)
- Power supply : +12 V
- Drive clock level : CMOS output under 5 V operation
- On-chip circuit : Automatic ϕ R level adjuster

ORDERING INFORMATION

Part Number	Package
μ PD3739D	CCD linear image sensor 22-pin ceramic DIP (CERDIP) (10.16 mm (400))

The information in this document is subject to change without notice. Before using this document, please confirm that this is the latest version.
Not all products and/or types are available in every country. Please check with an NEC Electronics sales representative for availability and additional information.

BLOCK DIAGRAM

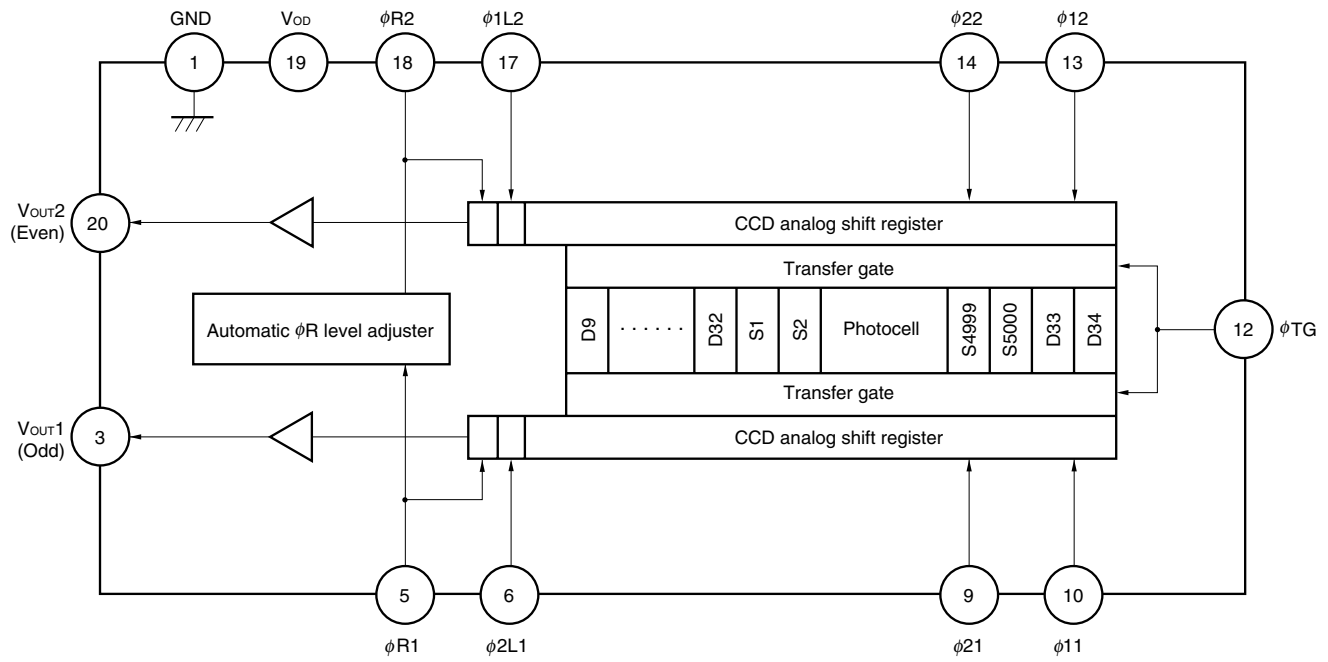

PIN CONFIGURATION (Top View)

CCD linear image sensor 22-pin ceramic DIP (CERDIP) (10.16 mm (400 mil))

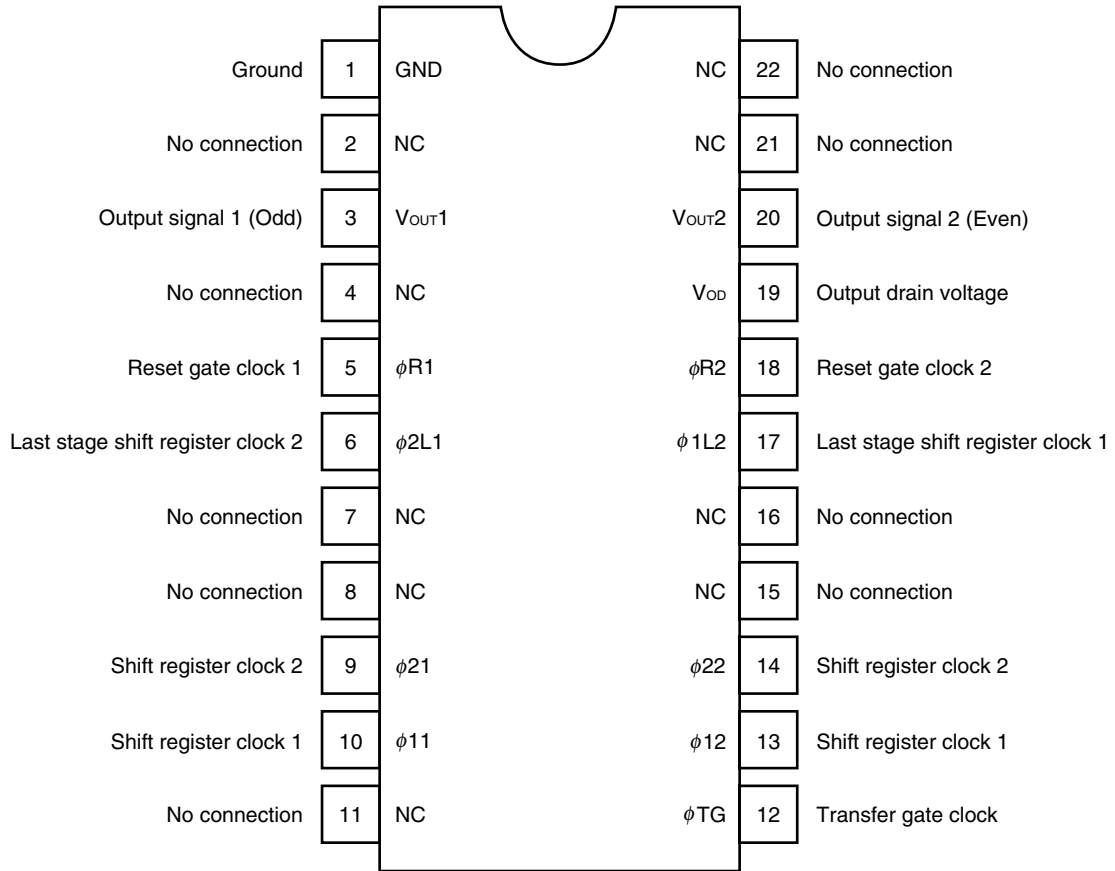

Caution Connect the No connection pins (NC) to GND.

PHOTOCELL STRUCTURE DIAGRAM

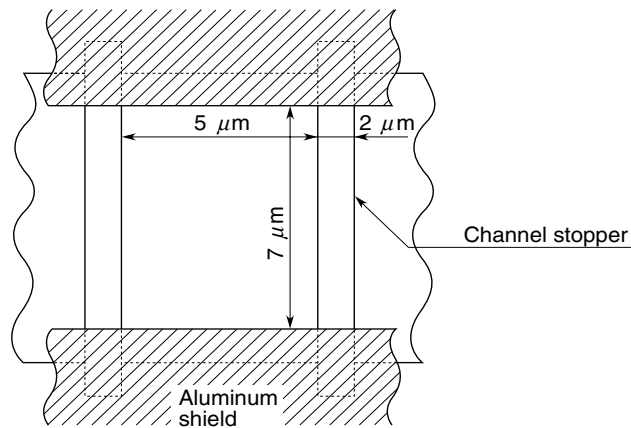

ABSOLUTE MAXIMUM RATINGS (T_A = +25°C)

Parameter	Symbol	Ratings	Unit
Output drain voltage	V _{OD}	-0.3 to +15	V
Shift register clock voltage	V _{φ1} , V _{φ2}	-0.3 to +15	V
Reset gate clock voltage	V _{φR1} , V _{φR2}	-0.3 to +15	V
Transfer gate clock voltage	V _{φTG}	-0.3 to +15	V
Operating ambient temperature ^{Note}	T _A	-25 to +55	°C
Storage temperature	T _{stg}	-40 to +100	°C

Note Use at the condition without dew condensation.

Caution Product quality may suffer if the absolute maximum rating is exceeded even momentarily for any parameter. That is, the absolute maximum ratings are rated values at which the product is on the verge of suffering physical damage, and therefore the product must be used under conditions that ensure that the absolute maximum ratings are not exceeded.

RECOMMENDED OPERATING CONDITIONS (T_A = -25 to +55°C)

Parameter	Symbol	Conditions	MIN.	TYP.	MAX.	Unit
Output drain voltage	V _{OD}		11.4	12.0	12.6	V
Shift register clock high level	V _{φ1H} , V _{φ2H}		4.5	5.0	5.5	V
Shift register clock low level	V _{φ1L} , V _{φ2L}		-0.3	0	+0.5	V
Reset gate clock high level	V _{φR1H} , V _{φR2H}	Note	4.5	5.0	5.5	V
Reset gate clock low level	V _{φR1L} , V _{φR2L}	Note	-0.3	0	+0.5	V
Capacitance of reset gate clock pin external capacitor	C _{EXTφR}	Non-polar type	800	1000	1200	pF
Transfer gate clock high level	V _{φTGH}		4.5	5.0	5.5	V
Transfer gate clock low level	V _{φTGL}		-0.3	0	+0.5	V
Data rate	2f _{φR1} , 2f _{φR2}		0.5	2	40	MHz

Note Input the reset gate clocks 1 and 2 (φR1, φR2) to pins 5 and 18, respectively, via an input resistor and a capacitor. Use of a capacitor is indispensable. Refer to **APPLICATION CIRCUIT EXAMPLE** for the connection method. The reset gate clock high level and low level at the IC pins (after passing through the external capacitor) varies according to the IC, due to the on-chip automatic φR level adjuster. The recommended operating conditions of reset gate clocks 1, 2 (φR1, φR2) in the table above are for signals applied to the external capacitor.

Remark φ1 in the above tables represents φ11, φ12 and φ1L2. φ2 represents φ21, φ22 and φ2L1.

ELECTRICAL CHARACTERISTICS

($T_A = +25^{\circ}\text{C}$, $V_{OD} = 12\text{ V}$, $f_{\phi 1} = 1\text{ MHz}$, data rate = 2 MHz, storage time = 10 ms
 light source: 3200 K halogen lamp + C-500S (infrared cut filter, t = 1 mm), input signal clock = 5 V_{p-p})

Parameter	Symbol	Test Conditions	MIN.	TYP.	MAX.	Unit
Saturation voltage	V_{sat}		1.0	1.5	—	V
Saturation exposure	SE	Daylight color fluorescent lamp	—	0.17	—	lx•s
Photo response non-uniformity	PRNU	$V_{OUT} = 500\text{ mV}$	—	4	10	%
Average dark signal	ADS	Light shielding	—	0.3	3.0	mV
Dark signal non-uniformity	DSNU	Light shielding	0	4.0	6.0	mV
Power consumption	P_w		—	200	400	mW
Output impedance	Z_o		—	0.2	0.5	kΩ
Response	R_F	Daylight color fluorescent lamp	7.2	9.0	10.8	V/lx•s
Response peak			—	550	—	nm
Image lag	IL	$V_{OUT} = 1\text{ V}$	—	0.3	1.0	%
Offset level Note 1	V_{OS}		2.0	3.5	5.0	V
Output fall delay time Note 2	t_d	$V_{OUT} = 1\text{ V}$	—	20	—	ns
Register imbalance	RI	$V_{OUT} = 500\text{ mV}$	0	—	4.0	%
Total transfer efficiency	TTE	$V_{OUT} = 500\text{ mV}$, data rate = 40 MHz	92	98	—	%
Dynamic range	DR1	$V_{sat}/DSNU$	—	375	—	times
	DR2	V_{sat}/σ	—	2143	—	times
Reset feed-through noise Note 1	RFTN	Light shielding	0	400	600	mV
Random noise	σ	Light shielding	—	0.7	—	mV

Notes 1. Refer to **TIMING CHART 2, 5**.

2. Typical value when the respective fall times of $\phi 1L2$ and $\phi 2L1$ are t_{11}' , t_{41}' and t_{2}' , t_{32}' (refer to **TIMING CHART 2, 5**). Note that V_{OUT1} and V_{OUT2} are the outputs of the two steps of emitter-follower shown in **APPLICATION CIRCUIT EXAMPLE**.

INPUT PIN CAPACITANCE (T_A = +25°C, V_{OD} = 12 V)

Parameter	Symbol	Pin name	Pin No.	MIN.	TYP.	MAX.	Unit
Shift register clock pin capacitance 1	C _{φ1}	φ11	10	250	350	500	pF
		φ12	13	250	350	500	pF
Shift register clock pin capacitance 2	C _{φ2}	φ21	9	250	350	500	pF
		φ22	14	250	350	500	pF
Last stage shift register clock pin capacitance	C _{φL}	φ1L2	17	40	50	100	pF
		φ2L1	6	40	50	100	pF
Reset gate clock pin capacitance	C _{φR}	φR1	5	8	10	15	pF
		φR2	18	8	10	15	pF
Transfer gate clock pin capacitance	C _{φTG}	φTG	12	100	150	200	pF

★ TIMING CHART 1 (Out of phase operation)

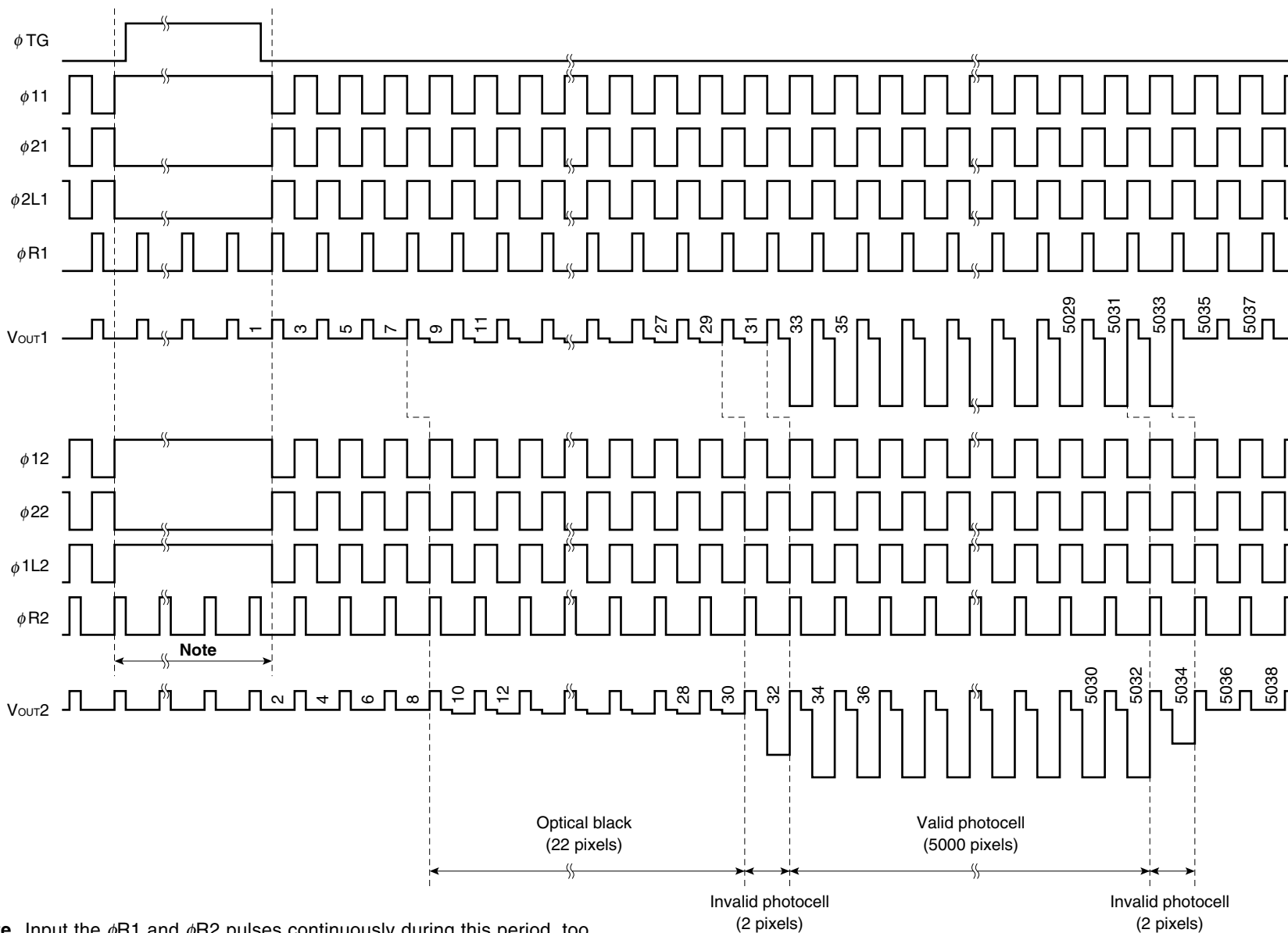

Note Input the ϕ R1 and ϕ R2 pulses continuously during this period, too.

TIMING CHART 3 (Out of phase operation)

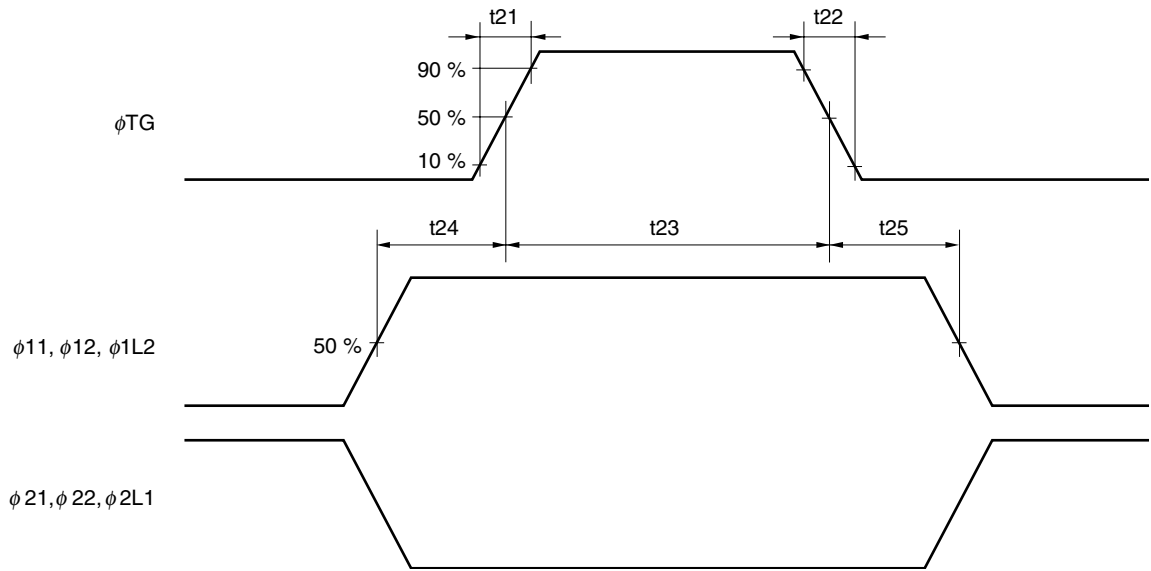

ϕ_{11}, ϕ_{21} cross points

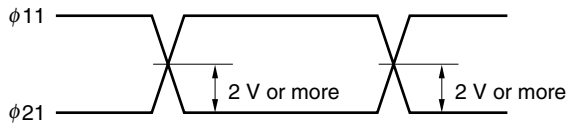

ϕ_{12}, ϕ_{22} cross points

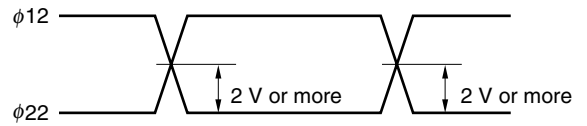

ϕ_{11}, ϕ_{2L1} cross points

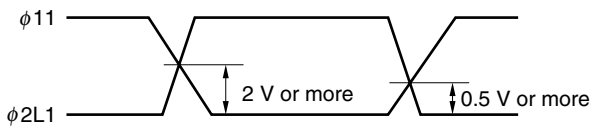

ϕ_{1L2}, ϕ_{22} cross points

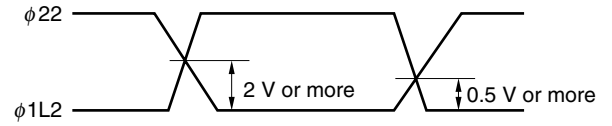

Remark Adjust cross points of (ϕ_{11}, ϕ_{21}), (ϕ_{12}, ϕ_{22}), (ϕ_{11}, ϕ_{2L1}) and (ϕ_{1L2}, ϕ_{22}) with input resistance of each pin.

Symbol	MIN.	TYP.	MAX.	Unit
t1, t2, t11, t12	0	50	—	ns
t1', t2', t11', t12'	0	5	—	ns
t3, t13	15	50	—	ns
t4, t14	5	20	—	ns
t5, t6, t15, t16	0	20	—	ns
t7, t7', t17, t17'	25	—	—	ns
t21, t22	0	50	—	ns
t23	1000	2000	5000	ns
t24, t25	10	100	—	ns

★ TIMING CHART 4 (In phase operation)

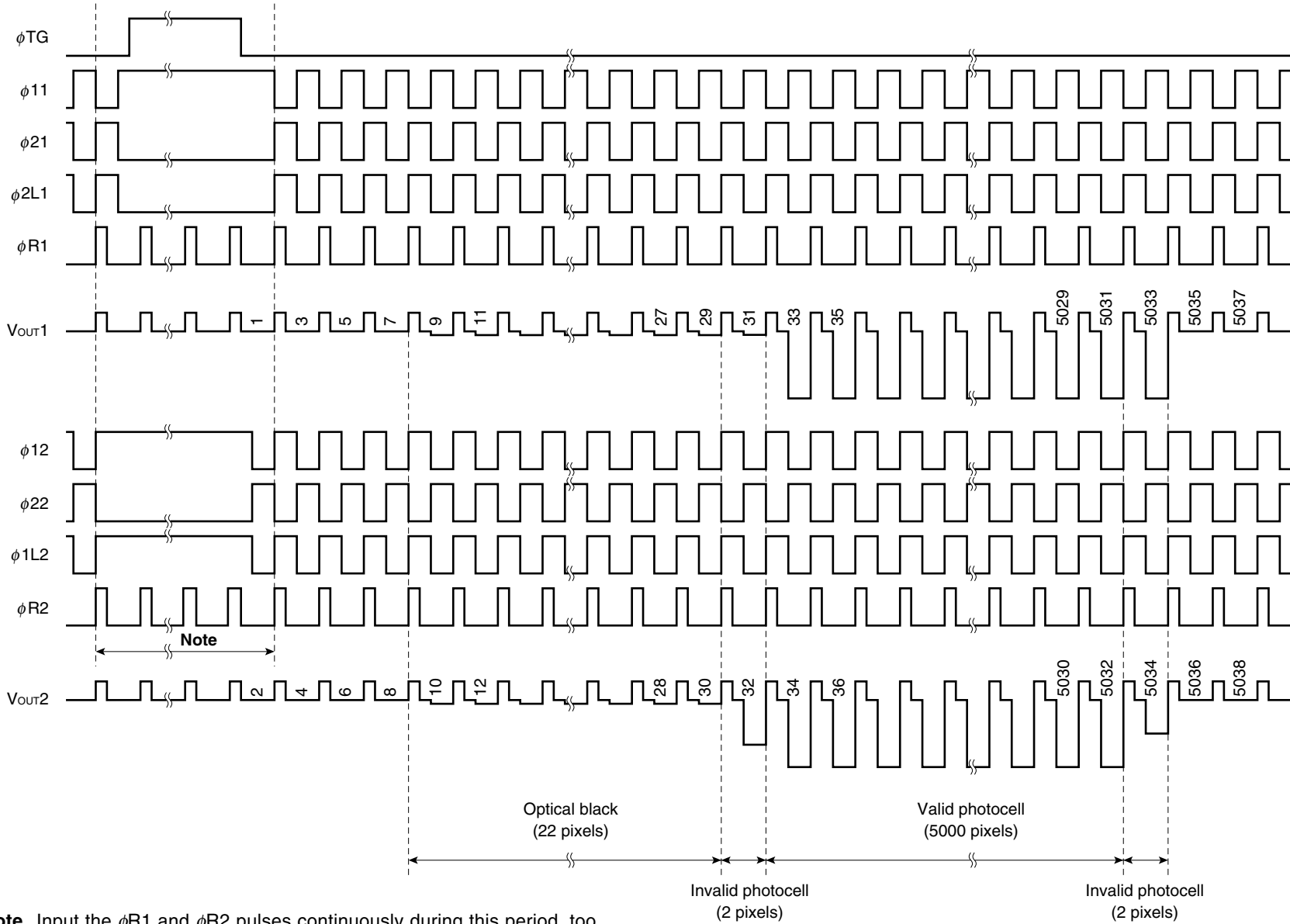

Note Input the ϕ_{R1} and ϕ_{R2} pulses continuously during this period, too.

TIMING CHART 5 (In phase operation)

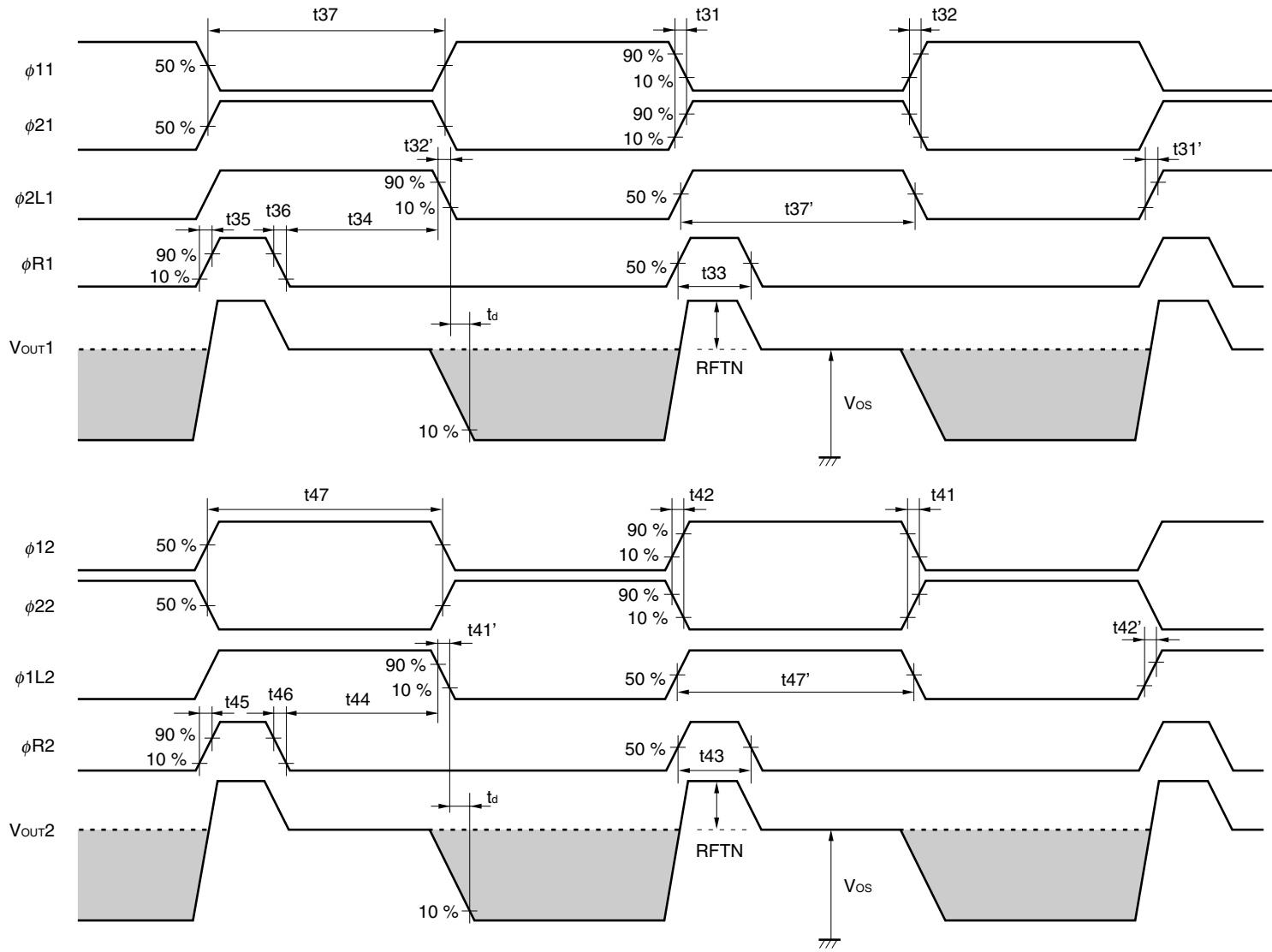

TIMING CHART 6 (In phase operation)

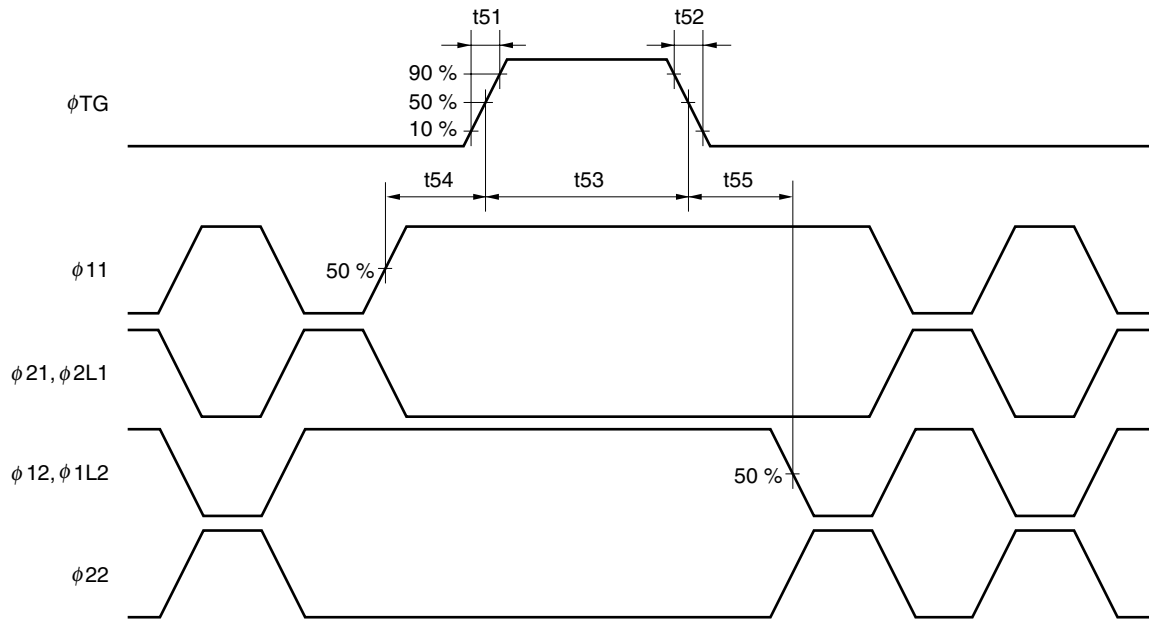

$\phi 11$, $\phi 21$ cross points

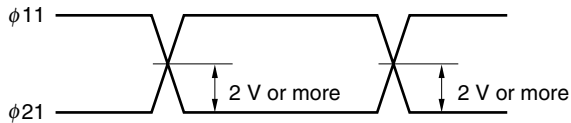

$\phi 12$, $\phi 22$ cross points

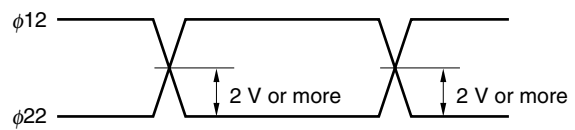

$\phi 11$, $\phi 2L1$ cross points

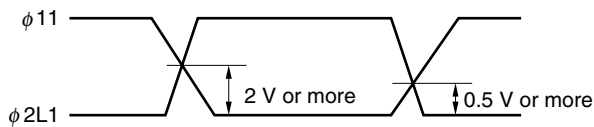

$\phi 1L2$, $\phi 22$ cross points

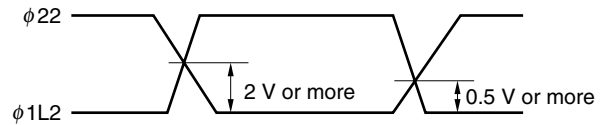

Remark Adjust cross points of ($\phi 11$, $\phi 21$), ($\phi 12$, $\phi 22$), ($\phi 11$, $\phi 2L1$) and ($\phi 1L2$, $\phi 22$) with input resistance of each pin.

Symbol	MIN.	TYP.	MAX.	Unit
t31, t32, t41, t42	0	50	—	ns
t31', t32', t41', t42'	0	5	—	ns
t33, t43	15	50	—	ns
t34, t44	5	20	—	ns
t35, t36, t45, t46	0	20	—	ns
t37, t37', t47, t47'	25	—	—	ns
t51, t52	0	50	—	ns
t53	1000	2000	5000	ns
t54, t55	10	100	—	ns

DEFINITIONS OF CHARACTERISTIC ITEMS

1. Saturation voltage: V_{sat}
Output signal voltage at which the response linearity is lost.
2. Saturation exposure: SE
Product of intensity of illumination (lx) and storage time(s) when saturation of output voltage occurs.
3. Photo response non-uniformity: PRNU
The output signal non-uniformity of all the valid pixels when the photosensitive surface is applied with the light of uniform illumination. This is calculated by the following formula.

$$PRNU (\%) = \frac{\Delta x}{\bar{x}} \times 100$$

Δx : maximum of $|x_j - \bar{x}|$

$$\bar{x} = \frac{\sum_{j=1}^{5000} x_j}{5000}$$

x_j : Output voltage of valid pixel number j

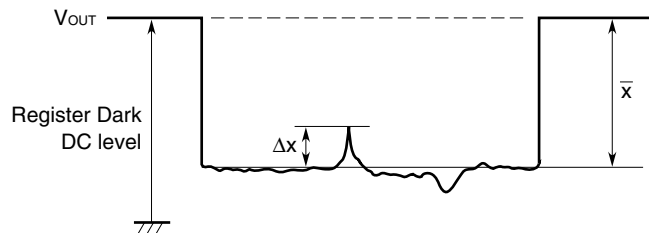

4. Average dark signal: ADS
Average output signal voltage of all the valid pixels at light shielding. This is calculated by the following formula.

$$ADS (mV) = \frac{\sum_{j=1}^{5000} d_j}{5000}$$

d_j : Dark signal of valid pixel number j

5. Dark signal non-uniformity: DSNU

Absolute maximum of the difference between ADS and voltage of the highest or lowest output pixel of all the valid pixels at light shielding. This is calculated by the following formula.

$$\text{DSNU (mV): maximum of } |d_j - \text{ADS}|_{j=1 \text{ to } 5000}$$

d_j : Dark signal of valid pixel number j

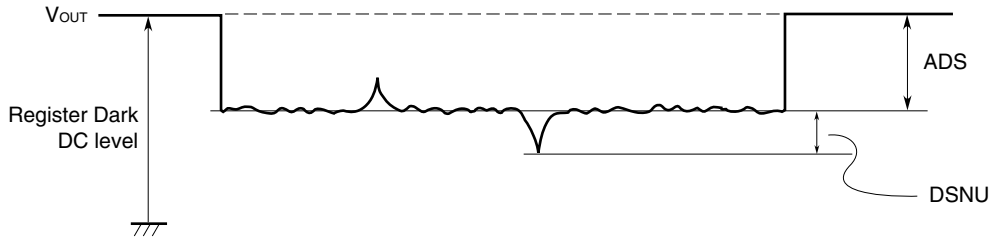

6. Output impedance: Z_o

Impedance of the output pins viewed from outside.

7. Response: R

Output voltage divided by exposure ($\text{lx}\cdot\text{s}$).

Note that the response varies with a light source (spectral characteristic).

8. Image lag: IL

The rate between the last output voltage and the next one after read out the data of a line.

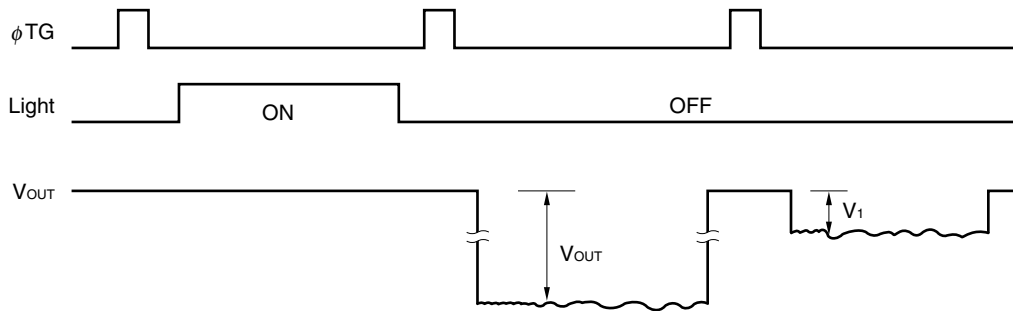

$$\text{IL (\%)} = \frac{V_1}{V_{\text{OUT}}} \times 100$$

9. Register imbalance: RI

The rate of the difference between the averages of the output voltage of Odd and Even pixels, against the average output voltage of all the valid pixels.

$$RI (\%) = \frac{\frac{2}{n} \left| \sum_{j=1}^{\frac{n}{2}} (V_{2j-1} - V_{2j}) \right|}{\frac{1}{n} \sum_{j=1}^n V_j} \times 100$$

n : Number of valid pixels

V_j : Output voltage of each pixel

10. Random noise: σ

Random noise σ is defined as the standard deviation of a valid pixel output signal with 100 times (=100 lines) data sampling at dark (light shielding).

$$\sigma \text{ (mV)} = \sqrt{\frac{\sum_{i=1}^{100} (V_i - \bar{V})^2}{100}}, \quad \bar{V} = \frac{1}{100} \sum_{i=1}^{100} V_i$$

V_i : A valid pixel output signal among all of the valid pixels

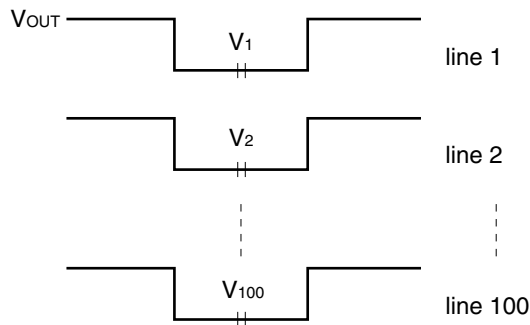

This is measured by the DC level sampling of only the signal level, not by CDS (Correlated Double Sampling).

STANDARD CHARACTERISTIC CURVES (Reference Value)

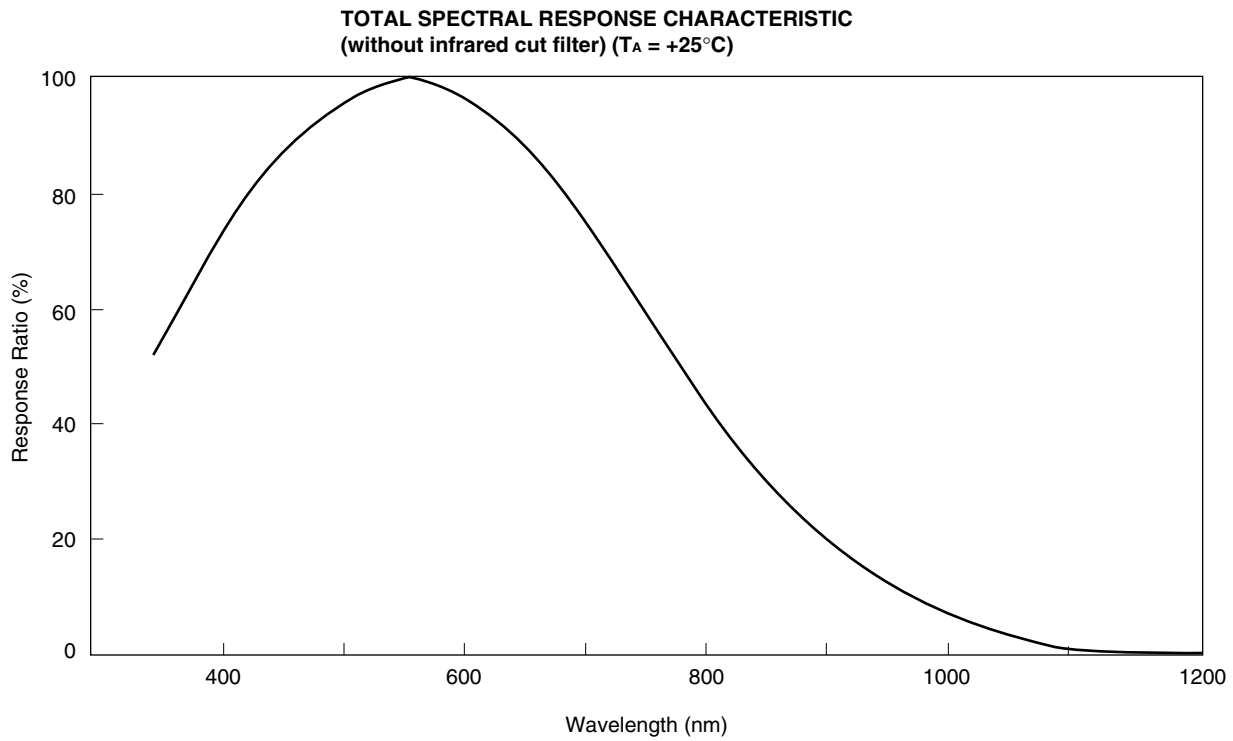
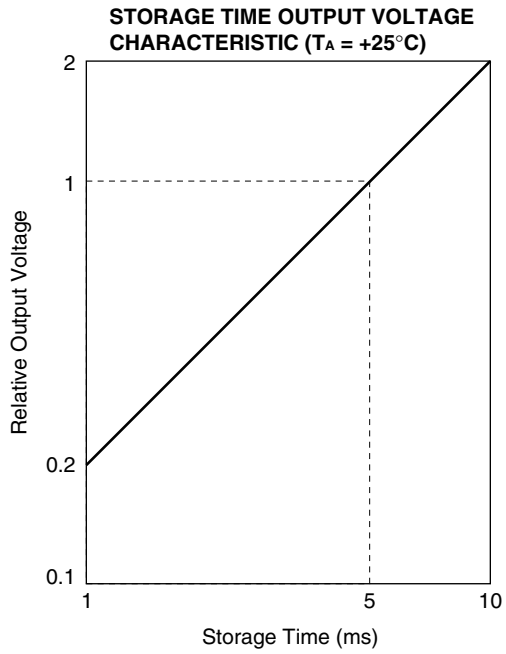
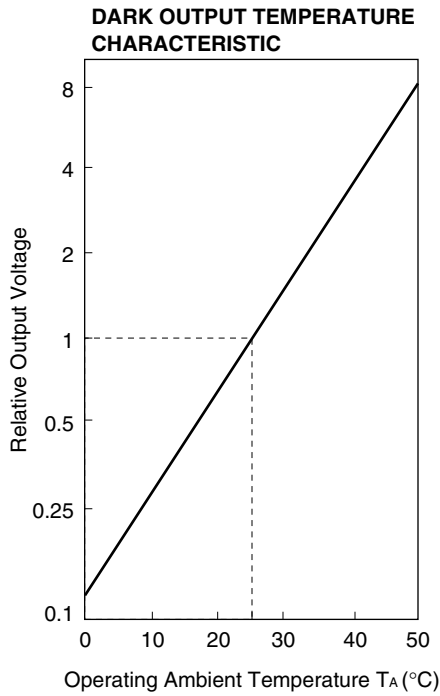

APPLICATION CIRCUIT EXAMPLE (Out of phase operation)

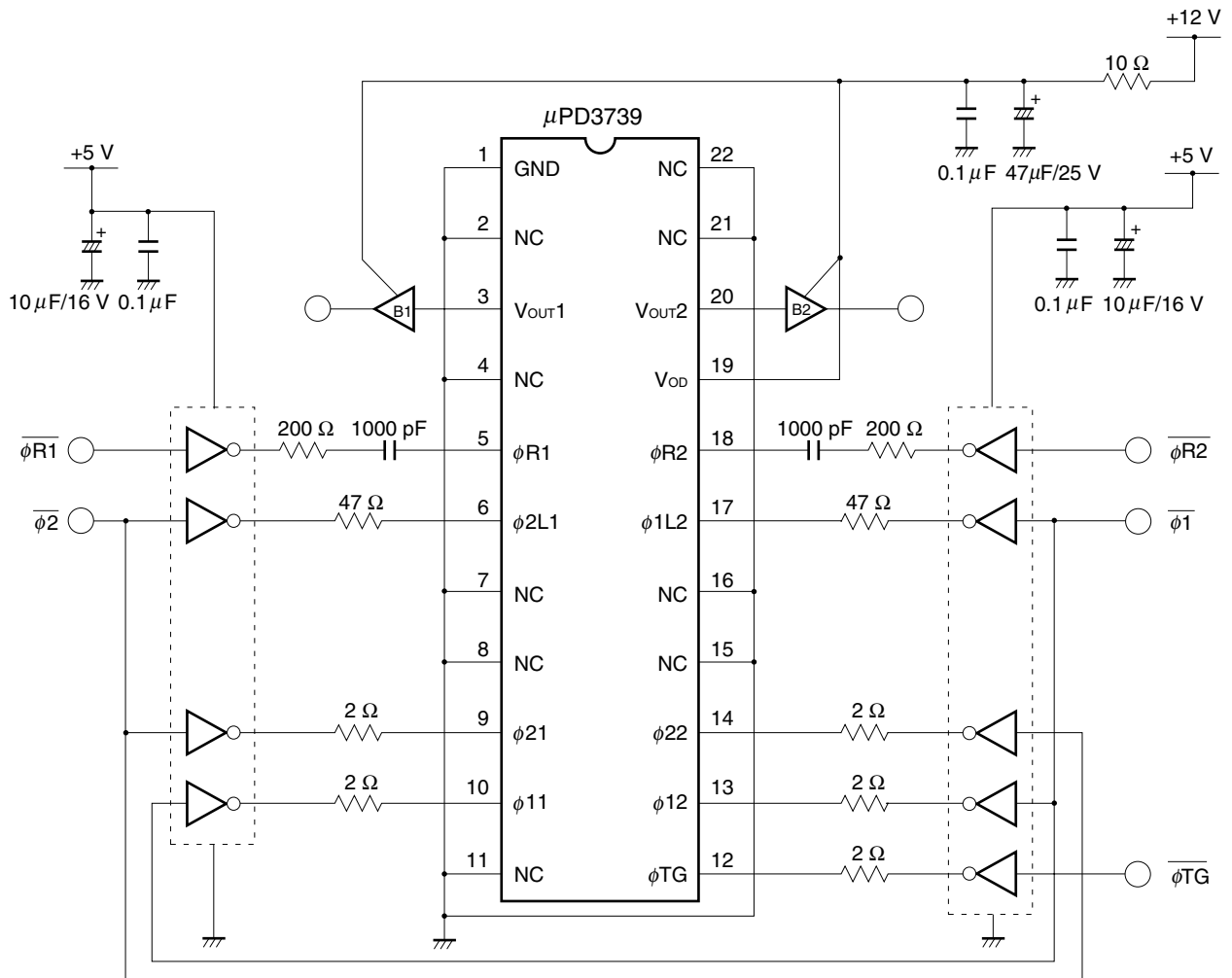

Caution Connect the No connection pins (NC) to GND.

- Remarks**
1. The μ PD3739 can be operated leaving pin 2 (NC) unconnected, and connecting pin 4 (NC) and pin 11 (NC) to a +12 V power supply.
 2. It is recommended that pins 6 (ϕ 2L1) and 17 (ϕ 1L2) each is separately driven a driver other than that of pins 10, 13 (ϕ 11, ϕ 12) and pins 9, 14 (ϕ 21, ϕ 22).
 3. The inverters shown in the above application circuit example are the 74AC04.

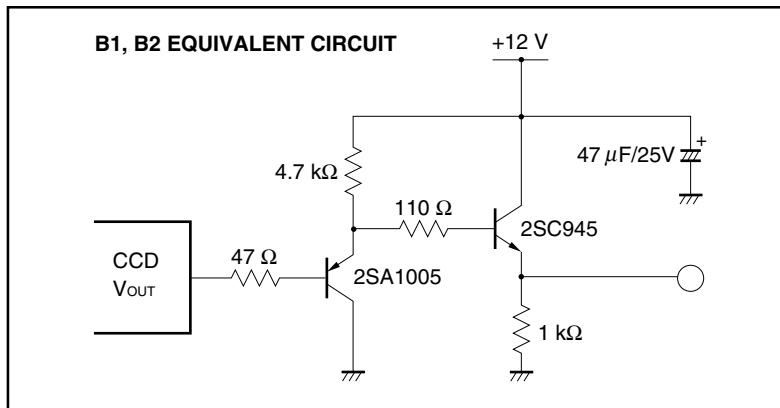

★ PACKAGE DRAWING

μPD3739D
 CCD LINEAR IMAGE SENSOR 22-PIN CERAMIC DIP (CERDIP) (10.16 mm (400))

(Unit : mm)

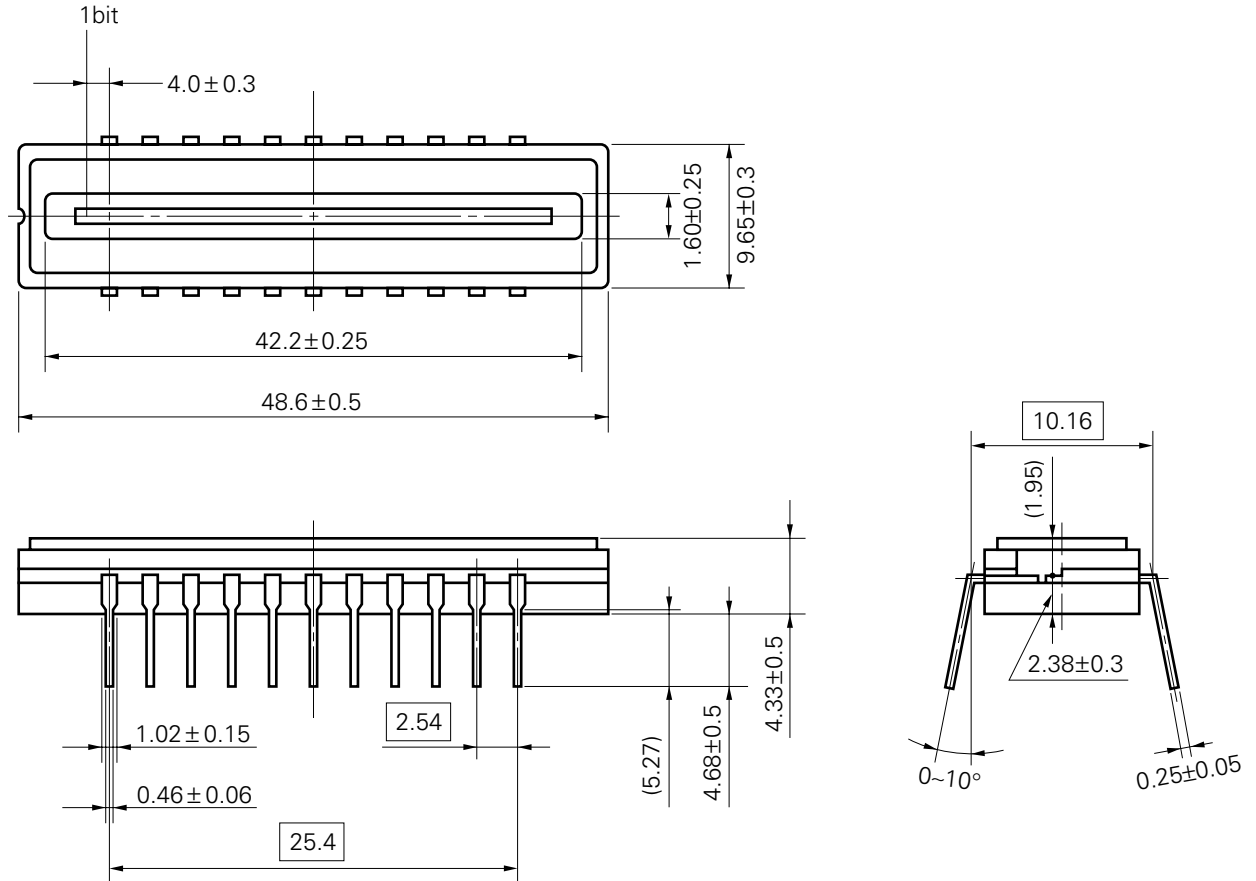

Name	Dimensions	Refractive index
Glass cap	47.5×9.25×0.7	1.5

22D-1CCD-PKG8-1

★ **RECOMMENDED SOLDERING CONDITIONS**

When soldering this product, it is highly recommended to observe the conditions as shown below.

If other soldering processes are used, or if the soldering is performed under different conditions, please make sure to consult with our sales offices.

Type of Through-hole Device

μPD3739D: CCD linear image sensor 22-pin ceramic DIP (CERDIP) (10.16 mm (400))

Process	Conditions
Partial heating method	Pin temperature: 300°C or below, Heat time: 3 seconds or less (per pin).

- Cautions**
1. **During assembly care should be taken to prevent solder or flux from contacting the glass cap. The optical characteristics could be degraded by such contact.**
 2. **Soldering by the solder flow method may have deleterious effects on prevention of glass cap soiling and heat resistance. So the method cannot be guaranteed.**

★

NOTES ON HANDLING THE PACKAGES

① MOUNTING OF THE PACKAGE

The application of an excessive load to the package may cause the package to warp or break, or cause chips to come off internally. Particular care should be taken when mounting the package on the circuit board. Don't have any object come in contact with glass cap. You should not reform the lead frame. We recommended to use a IC-inserter when you assemble to PCB.

Also, be care that the any of the following can cause the package to crack or dust to be generated.

1. Applying heat to the external leads for an extended period of time with soldering iron.
2. Applying repetitive bending stress to the external leads.
3. Rapid cooling or heating

② GLASS CAP

Don't either touch glass cap surface by hand or have any object come in contact with glass cap surface. Care should be taken to avoid mechanical or thermal shock because the glass cap is easily to damage. For dirt stuck through electricity ionized air is recommended.

③ OPERATE AND STORAGE ENVIRONMENTS

Operate in clean environments. CCD image sensors are precise optical equipment that should not be subject to mechanical shocks. Exposure to high temperatures or humidity will affect the characteristics. So avoid storage or usage in such conditions.

Keep in a case to protect from dust and dirt. Dew condensation may occur on CCD image sensors when the devices are transported from a low-temperature environment to a high-temperature environment. Avoid such rapid temperature changes.

For more details, refer to our document "Review of Quality and Reliability Handbook" (C12769E)

④ ELECTROSTATIC BREAKDOWN

CCD image sensor is protected against static electricity, but destruction due to static electricity is sometimes detected. Before handling be sure to take the following protective measures.

1. Ground the tools such as soldering iron, radio cutting pliers or pincer.
2. Install a conductive mat or on the floor or working table to prevent the generation of static electricity.
3. Either handle bare handed or use non-chargeable gloves, clothes or material.
4. Ionized air is recommended for discharge when handling CCD image sensor.
5. For the shipment of mounted substrates, use box treated for prevention of static charges.
6. Anyone who is handling CCD image sensors, mounting them on PCBs or testing or inspecting PCBs on which CCD image sensors have been mounted must wear anti-static bands such as wrist straps and ankle straps which are grounded via a series resistance connection of about 1 MΩ.

NOTES FOR CMOS DEVICES**① PRECAUTION AGAINST ESD FOR SEMICONDUCTORS**

Note:

Strong electric field, when exposed to a MOS device, can cause destruction of the gate oxide and ultimately degrade the device operation. Steps must be taken to stop generation of static electricity as much as possible, and quickly dissipate it once, when it has occurred. Environmental control must be adequate. When it is dry, humidifier should be used. It is recommended to avoid using insulators that easily build static electricity. Semiconductor devices must be stored and transported in an anti-static container, static shielding bag or conductive material. All test and measurement tools including work bench and floor should be grounded. The operator should be grounded using wrist strap. Semiconductor devices must not be touched with bare hands. Similar precautions need to be taken for PW boards with semiconductor devices on it.

② HANDLING OF UNUSED INPUT PINS FOR CMOS

Note:

No connection for CMOS device inputs can be cause of malfunction. If no connection is provided to the input pins, it is possible that an internal input level may be generated due to noise, etc., hence causing malfunction. CMOS devices behave differently than Bipolar or NMOS devices. Input levels of CMOS devices must be fixed high or low by using a pull-up or pull-down circuitry. Each unused pin should be connected to V_{DD} or GND with a resistor, if it is considered to have a possibility of being an output pin. All handling related to the unused pins must be judged device by device and related specifications governing the devices.

③ STATUS BEFORE INITIALIZATION OF MOS DEVICES

Note:

Power-on does not necessarily define initial status of MOS device. Production process of MOS does not define the initial operation status of the device. Immediately after the power source is turned ON, the devices with reset function have not yet been initialized. Hence, power-on does not guarantee out-pin levels, I/O settings or contents of registers. Device is not initialized until the reset signal is received. Reset operation must be executed immediately after power-on for devices having reset function.

[MEMO]

• **The information in this document is current as of November, 2002. The information is subject to change without notice. For actual design-in, refer to the latest publications of NEC Electronics data sheets or data books, etc., for the most up-to-date specifications of NEC Electronics products. Not all products and/or types are available in every country. Please check with an NEC Electronics sales representative for availability and additional information.**

- No part of this document may be copied or reproduced in any form or by any means without the prior written consent of NEC Electronics. NEC Electronics assumes no responsibility for any errors that may appear in this document.
- NEC Electronics does not assume any liability for infringement of patents, copyrights or other intellectual property rights of third parties by or arising from the use of NEC Electronics products listed in this document or any other liability arising from the use of such products. No license, express, implied or otherwise, is granted under any patents, copyrights or other intellectual property rights of NEC Electronics or others.
- Descriptions of circuits, software and other related information in this document are provided for illustrative purposes in semiconductor product operation and application examples. The incorporation of these circuits, software and information in the design of a customer's equipment shall be done under the full responsibility of the customer. NEC Electronics assumes no responsibility for any losses incurred by customers or third parties arising from the use of these circuits, software and information.
- While NEC Electronics endeavors to enhance the quality, reliability and safety of NEC Electronics products, customers agree and acknowledge that the possibility of defects thereof cannot be eliminated entirely. To minimize risks of damage to property or injury (including death) to persons arising from defects in NEC Electronics products, customers must incorporate sufficient safety measures in their design, such as redundancy, fire-containment and anti-failure features.
- NEC Electronics products are classified into the following three quality grades: "Standard", "Special" and "Specific".

The "Specific" quality grade applies only to NEC Electronics products developed based on a customer-designated "quality assurance program" for a specific application. The recommended applications of an NEC Electronics product depend on its quality grade, as indicated below. Customers must check the quality grade of each NEC Electronics product before using it in a particular application.

"Standard": Computers, office equipment, communications equipment, test and measurement equipment, audio and visual equipment, home electronic appliances, machine tools, personal electronic equipment and industrial robots.

"Special": Transportation equipment (automobiles, trains, ships, etc.), traffic control systems, anti-disaster systems, anti-crime systems, safety equipment and medical equipment (not specifically designed for life support).

"Specific": Aircraft, aerospace equipment, submersible repeaters, nuclear reactor control systems, life support systems and medical equipment for life support, etc.

The quality grade of NEC Electronics products is "Standard" unless otherwise expressly specified in NEC Electronics data sheets or data books, etc. If customers wish to use NEC Electronics products in applications not intended by NEC Electronics, they must contact an NEC Electronics sales representative in advance to determine NEC Electronics' willingness to support a given application.

(Note)

- (1) "NEC Electronics" as used in this statement means NEC Electronics Corporation and also includes its majority-owned subsidiaries.
- (2) "NEC Electronics products" means any product developed or manufactured by or for NEC Electronics (as defined above).