



# OWL CAM/CMOS-2KRDI.LS

## Ultra Low Noise High Speed CMOS Linescan Camera for Scientific and Industrial Applications

The Owl™ is an ultra-sensitive camera for use in line scan applications that demand high performance under low light conditions. The camera is based upon a 2K CMOS linear sensor that utilizes patented Active Reset Technology to obtain very low noise performance while operating at very high data rates. The 2K RDI (**Read-outs During Integration**) camera provides a high line rate as the sensor is reading out the previous line of data while integrating the current line. The 12-bit / 10-bit / 8-bit output of the camera utilizes industry standard Camera Link interface and will provide data at 80MHz (40MHz per output). The camera offers features such as anti-blooming and programmable gain and offset. It is packaged in a compact and rugged housing that supports standard M58, Nikon F-mount lenses, and C-mount lenses.



The CMOS linear sensor used in this camera has a unique feature that allows gain selection at the pixel level. In the high gain mode, the noise is minimized while in the low gain mode, the dynamic range is maximized.

### Features

#### Low Noise CMOS Linear Sensor

- Uses patented Active Reset Technology
- Unique combination of high speed and low noise

#### Full Featured Camera Electronics

- Single power supply
- Selectable pixel gain
- Programmable gain and offset

#### Standard Interface

- Camera Link compatible
- Connects to standard Camera Link frame grabbers
- 4-pin Hirose power connector
- MDR26 data and control connector

#### Applications

- Precision manufacturing inspection
- Web inspection
- Sorting and routing
- Biomedical readout systems
- Diagnostic systems

### Camera Performance (RDI)

Resolution:	2048 pixels
Pixel Size:	7µm x 7µm
Housing Size	3.92"H x 3.92"W x 1.84"D
Anti-blooming:	15,000 X
Output Ports:	Camera Link
Maximum Pixel Clock:	80 MHz
Maximum Data Rate:	80 MHz (40 MHz x 2)
Maximum Line Rate:	38 KHz
Gray Scale:	12-bit / 10-bit / 8-bit
Lens Mount:	M58
Lens Mount Adapter:	M58 to Nikon F-mount and M58 to C-mount (both optional)
Part Number:	CAM/CMOS-2KRDI.LS
Operating Temperature:	45°C
Dynamic Range:	High gain 620:1 Low gain 1050:1
Sensitivity/Responsivity:	High gain >750 DN/nJ/cm <sup>2</sup> Low gain > 100 DN/nJ/cm <sup>2</sup>
Noise Equivalent Exposure:	< 8 pJ/cm <sup>2</sup>
Saturation Equiv. Exposure:	High gain 4.8 nJ/cm <sup>2</sup> Low gain 32 nJ/cm <sup>2</sup>
Output Gain Range:	18 dB
Power Supply:	5 VDC
Power Dissipation:	< 2.5W
Regulatory Compliance:	CE, FCC

## Mechanical Dimensions

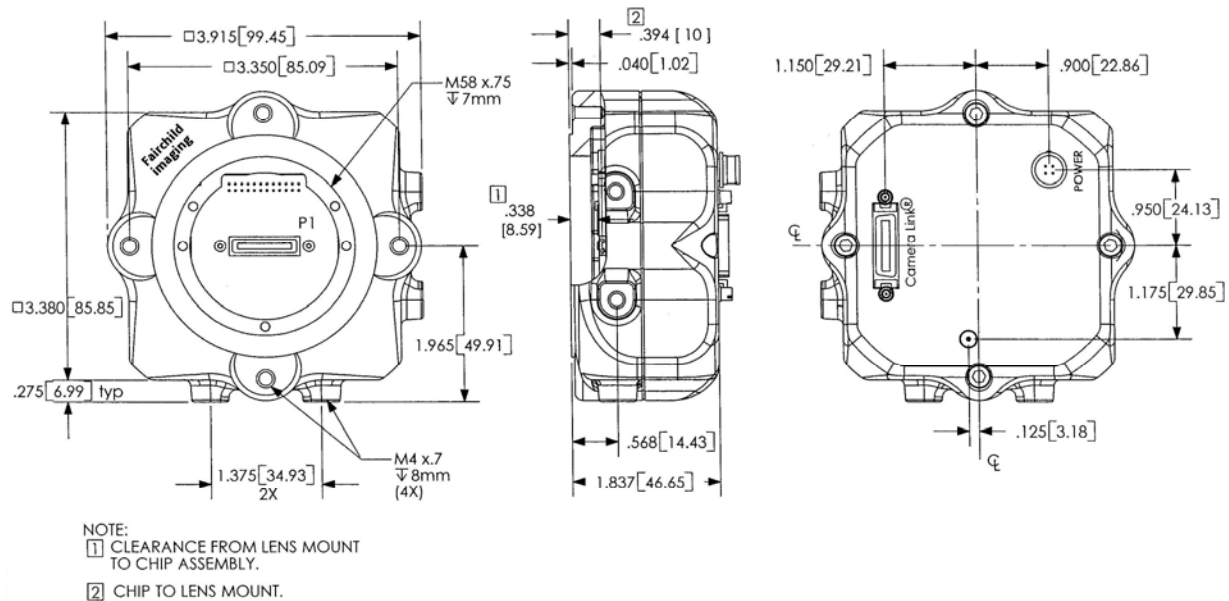

## Interface Requirements

### Power Supply

- 4-pin Hirose (HR25-7TR-4P)

### Data

- MDR26 Camera Link configured
- 40MHz per output

### Frame Grabber

- Standard Camera Link frame grabbers

### Control

- Via the Camera Link connectors



## Responsivity Curve

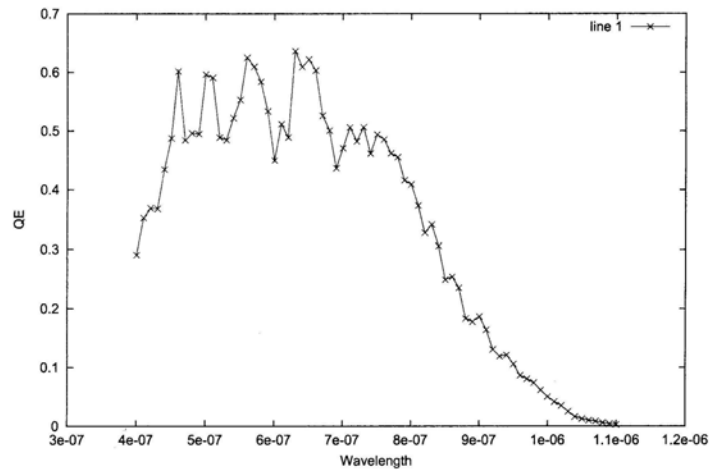

## WARRANTY

Within twelve months of delivery to the end customer, Fairchild Imaging will repair or replace, at our option, any Fairchild Imaging product if any part is found to be defective in materials or workmanship. Contact Customer Service for assignment of warranty for any Fairchild Imaging product if any part is found to be defective in materials or workmanship.

This product is designed, manufactured and distributed utilizing the ISO 9001:2000 Business Management System.

## Fairchild Imaging

1801 McCarthy Blvd., Milpitas CA 95035  
 (800) 325-6975 or (408) 433-2500

## CERTIFICATION

Fairchild Imaging certifies that all products are carefully inspected and tested at the factory prior to shipment and will meet all requirements of the specifications under which it is furnished.

©2003 Fairchild Imaging reserves the right to make changes to its products and/or their specifications at any time without notice. Printed in the U.S.A.