



# **OSPREY CAMERA SERIES**

## **CAM/CCD-2KLV.TDI**

## **CAM/CCD-4KLV.TDI**

### **ULTRA-HIGH PERFORMANCE**

### ***Line Scan Camera***

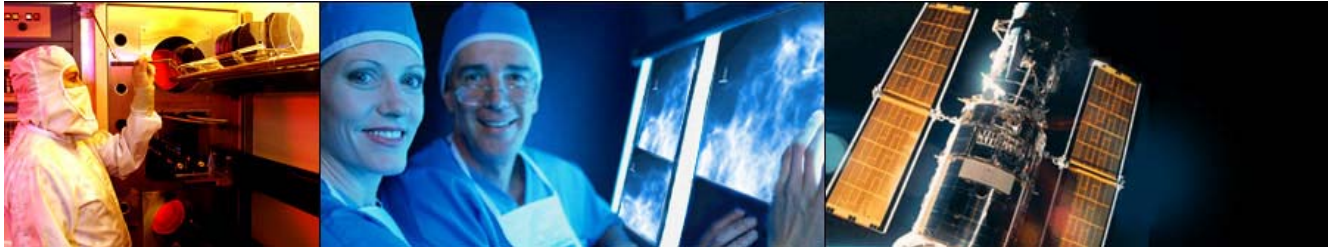

Camera User's Manual



## EMC Conformance

This equipment has been tested and found to comply with the limits for a Class A digital device, pursuant to Part 15 of the FCC Rules.

This product fulfills the following requirements of the standards and carries the CE marking.

EMC:       FCC Part 15, Subpart B  
              EN 6100-6-4:2001  
              EN 6100-6-2:2001  
              EN6100-3-2:2000  
              EN 6100-3-3:1995/A1:2001

**FAIRCHILD IMAGING**  
**OSPREY CAMERA SERIES**  
**USER'S MANUAL**  
**CAM/CCD-2KLV.TDI and CAM/CCD-4KLV.TDI**  
**Rev C**  
**December 14, 2004**

**© 2004 Fairchild Imaging, Inc.**

Fairchild Imaging, Inc.  
1801 McCarthy Blvd.  
Milpitas CA 95035  
1-800-325-6975  
[www.fairchildimaging.com](http://www.fairchildimaging.com)

**PRELIMINARY DOCUMENT**

The information in this manual is preliminary.

All information provided in this manual is believed to be correct at the time of writing. No responsibility is assumed by Fairchild Imaging for its use. Fairchild Imaging intends to make this manual as accurate as possible and reserves the right to make changes to this information without notice.

# Table of Contents

## SECTION 1

### Introduction to the CAM/CCD-2KLV.TDI and CAM/CCD-4KLV.TDI

#### High Performance TDI Line Scan Camera ..... 6

1.1 Camera Highlights .....	6
1.2 Camera Specification .....	7
1.3 Image Sensor.....	8
1.4 Block Diagram CCD525.....	9
1.5 Block Diagram CCD545.....	10
1.6 Block Diagram 2K and 4K TDI Camera .....	11
1.7 2K/4K TDI Camera Timing Diagram .....	12
1.8 Thermal Considerations.....	13

## SECTION 2

### Camera Hardware Interface ..... 14

2.1 Installation Overview.....	14
2.2 Connectors, Pinouts and Cables .....	15
2.3 Power Supply.....	17
2.4 LED Indicator Status Lamp .....	17

## SECTION 3

### Camera Control..... 18

3.1 Quick Start with LVDS Interface .....	18
3.2 Control Inputs.....	18
3.3 Providing External Triggering.....	19
3.4 Frame Grabber Receives Trigger .....	20
3.5 Frame Mode.....	21
3.6 System Connection.....	23
3.7 TDI Length Selection .....	24
3.8 Gain and Offset Calibration.....	25
3.9 How to Modify Gain & Offset Values.....	25
3.10 Data Bus .....	26

## SECTION 4

### Mechanical and Optical Considerations..... 27

4.1 Camera Dimensions and Mounting.....	27
4.2 Lenses .....	28
4.3 Mechanical Drawing of Optical Camera Face Mounting “L” Bracket .....	29
4.4 Lenses .....	29
4.5 Illumination.....	30
4.6 Light Sources .....	30
4.7 Lens Modeling.....	30
4.8 2K and 4K LVDS Cable Harness .....	31

<b>SECTION 5</b>	
<b>Handling Instructions .....</b>	<b>32</b>
5.1 Electrostatic Discharge .....	32
5.2 Preventing ESD Damage.....	32
5.3 Protecting Against Dust, Oil and Scratches .....	32
5.4 Cleaning the Sensor Window.....	32
<b>SECTION 6</b>	
<b>Troubleshooting.....</b>	<b>33</b>
6.1 Check Simple Things First.....	33
6.2 Use the Camera Control Interface to Perform Checks .....	33
6.3 Other Areas You Should Check.....	33
<b>SECTION 7</b>	
<b>Product Support.....</b>	<b>36</b>
<b>REFERENCE A</b>	
<b>Providing External Trigger Using PCI-1424 Frame Grabber.....</b>	<b>37</b>
<b>REFERENCE B</b>	
<b>Introduction to LVDS .....</b>	<b>38</b>

## SECTION 1

# Introduction to the CAM/CCD-2KLV.TDI and CAM/CCD-4KLV.TDI High Performance TDI Line Scan Camera

## 1.1 Camera Highlights

### Description

The Osprey TDI camera series is an ultra-sensitive camera design for use in line scan applications that demand high performance under low light conditions. This series of cameras is based upon Fairchild's CCD525 array, which is used in the very successful U.S. Postal Service Wide Field of View (WFOV) Camera. The 2K camera versions have 2048 pixels in the cross-scan direction, with selectable TDI stages up to 96 rows. The 4K varieties have 4096 pixels in the cross-scan direction, also with selectable TDI stages up to 96 rows. The 2K Osprey supports scan rates up to 46K lines per second while the 4K yields up to 23K lines per second. Both the 2K and 4K styles have LVDS outputs. The LVDS output supports 4-port, 8-bit synchronous data. This camera also includes sophisticated features such as anti-blooming, programmable gain and offset. It is packaged in a very compact and rugged housing that contains a standard M58 x 0.75 base lens thread. Optional (Nikon-F) lens adapter is available.

### 2K x 96 TDI Sensor Architecture

- Uses time delay and integration sensor architecture
- User selectable TDI lengths of 96, 64, 48, 32, 24
- Line rate up to 46K lines per sec
- 1000X antiblooming
- Non volatile gain/offset value memory
- <1 LSB Noise RMS

### 4K x 96 TDI Sensor Architecture

- Uses time delay and integration sensor architecture
- User selectable TDI lengths of 96, 64, 32, 16
- 25MHz pixel clock
- Non volatile gain/offset value memory
- <1 LSB Noise RMS

## Programmability

Simple menu-based configuration for selection of gain, offset operational control, and diagnostics.

- LVDS camera-PC communications with Fairchild-supplied user GUI.

## Usability

Programmable gain, offsets, and controls.

- Easy integration “plug compatible” LVDS hookup

## Full Spectrum of Applications

- Precision manufacturing inspection
- Web inspection
- Sorting and routing
- Biomedical readout systems
- Diagnostic systems

## 1.2 Camera Specification – CAM/CCD-2KLV.TDI & CAM/CCD-4KLV.TDI Performance Specification

Calibration Conditions	Units	Min.	2048 Typ.	Max.	Min	4096 Typ.	Max.	Notes
Data Rate (Strobe)	MHz		25	25		25	25	
Line Rate (LVAL)	KHz	0.3		46.0	0.3		23	8
<b>Functions</b>								
Saturation Output Amplitude	DN		250	255		250	255	
Output Gain Mismatch	DN		2	5		2	5	
Pixel Response Non-Uniformity Global (PRNU)	DN		5	12		5	12	
Tap	DN		4	10		4	10	1, 3,4
Pixel-Pixel	DN		4	10		4	10	7
Fixed Pattern Noise (FPN) Global	DN			3			3	3,4
Tap	DN			2			2	1, 3
Pixel-Pixel	DN			2			2	3, 4
DC Offset	DN		4			4		2
DC Offset Mismatch	DN			2			2	
Random Noise	DN		2	4		2	4	
Noise Equivalent Exposure	pJ/cm <sup>2</sup>			3			3	
Saturation Equivalent Exposure	nJ/cm <sup>2</sup>		1.0			1.0		
Responsivity	DN/(nJ/cm <sup>2</sup> )		250			250		
Dynamic Range	Ratio		360:1			360:1		
Power Supply Current @ 12VDC	mA		650			700		6,9
Power Supply Voltage	Volts	10.5	12.0	15.0	10.5	12.0	15.0	
Operating Temperature	°C			40			40	
First Pixel Mismatch	DN			10			10	5

**Notes:**

DN = Digital Numbers, also known as “levels” (0 – 255 for 8-bit systems, 0 – 4095 for 12-bit systems).

All measurements taken with camera operating in 96 stage mode.

All measurements exclude the last pixel of OS 1 and the first pixel of OS4.

Tested using Volpi (18111.001) light line source, default camera gain.

1. Measured across 1 tap (512 pixels – 2K) (1024 pixels – 4K).
2. Typical offset @ 20°C ambient with sensor covered.
3. Excludes last pixel of OS1 and first pixel of OS4.
4. Measured across all taps.
5. Measured on each tap relative to next ten pixels. Measured at 50% Vsat.
6. Measured with digital outputs, (terminated in 100 ohms).
7. A delta window of 8 pixels is examined and shifted by half its window. First and last pixel excluded from each tap.
8. Camera will operate below min. line rate with degraded performance.
9. Power supply must support >850 mA surge current.

### 1.3 Image Sensor

The family of Osprey cameras use the following Fairchild sensors: The 2K x 96 TDI camera uses the CCD525 sensor, and the 4K x 96 TDI camera uses the CCD545 sensor. Both sensors have 13µm square pixels on a 13µm pitch.

Both sensors are approximately 96 times more sensitive compared to line scan cameras.

## 1.4 Block Diagram CCD525

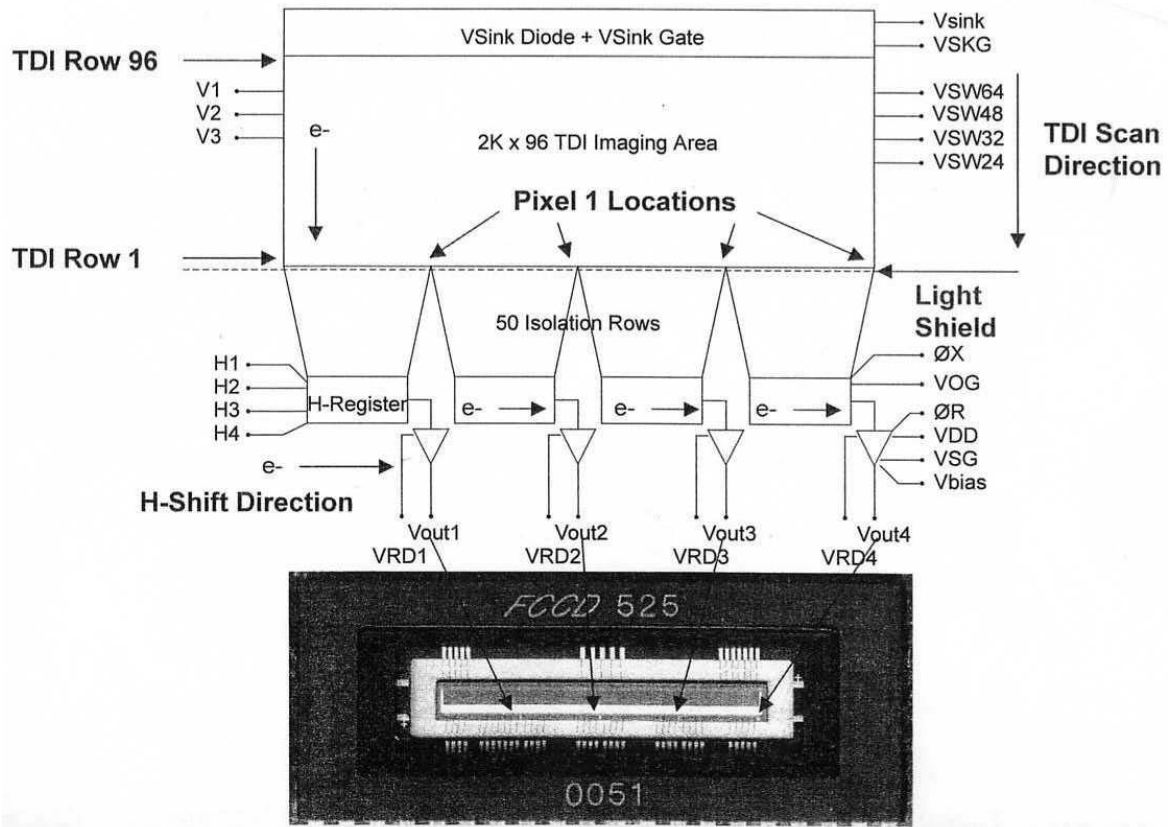

**2048 x 96 stages**

# 1.5 Block Diagram CCD545

4096 x 96 stages

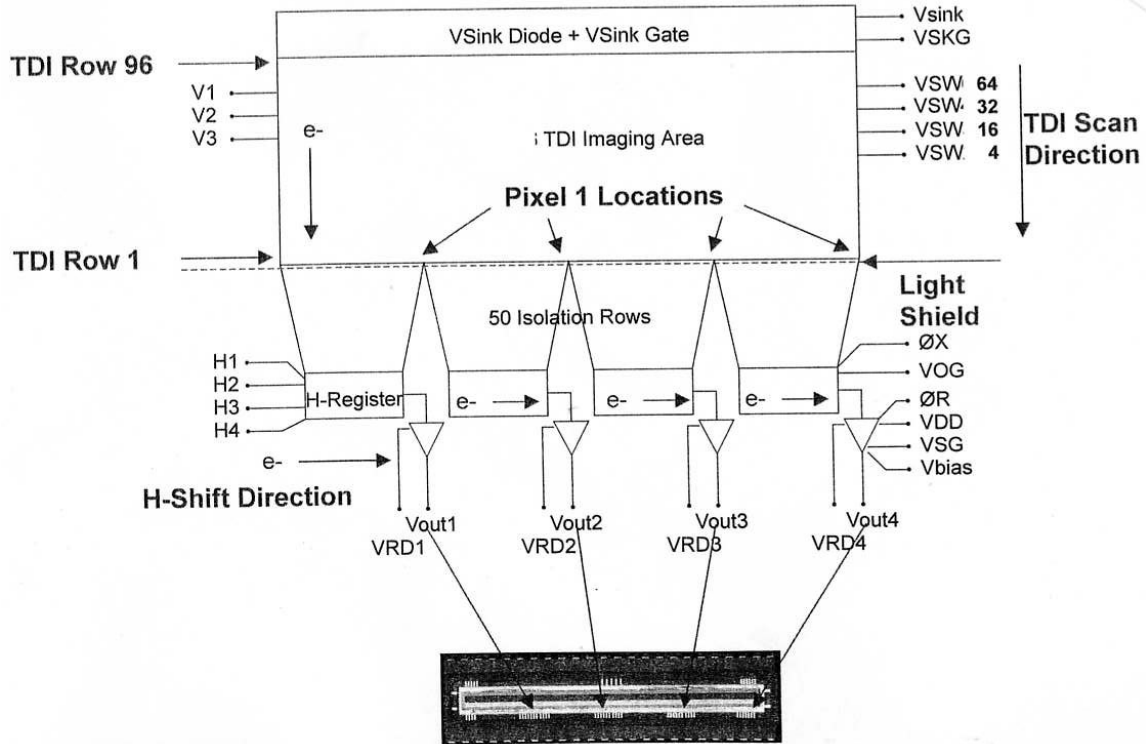

# 1.6 Block Diagram 2K & 4K TDI Camera

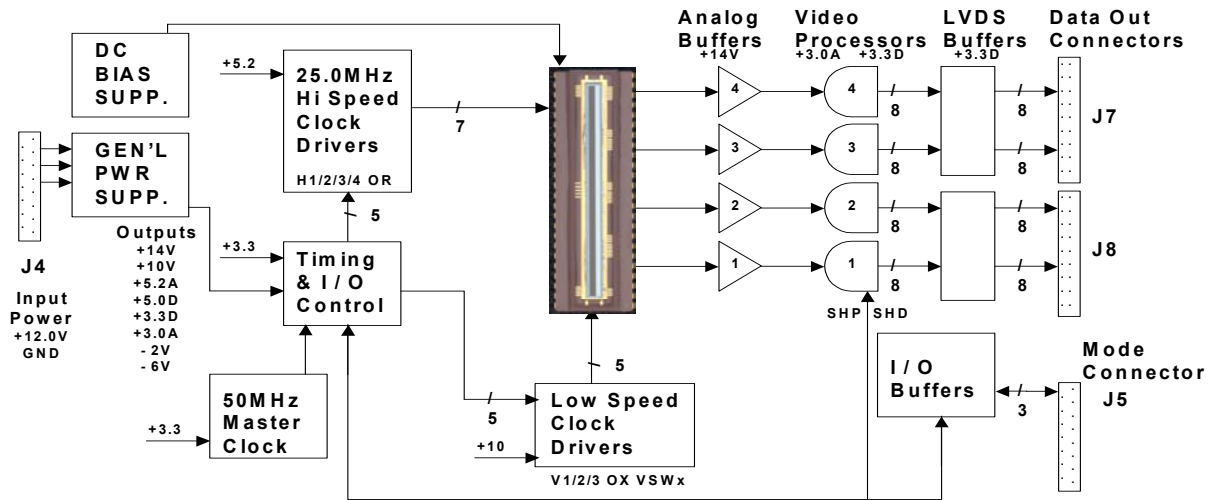

Fairchild Imaging

Fairchild CAM-4K TDI.ppt 4

## 1.7 2K/4K TDI Camera Timing Diagram

**Note:** Timing diagram not to scale

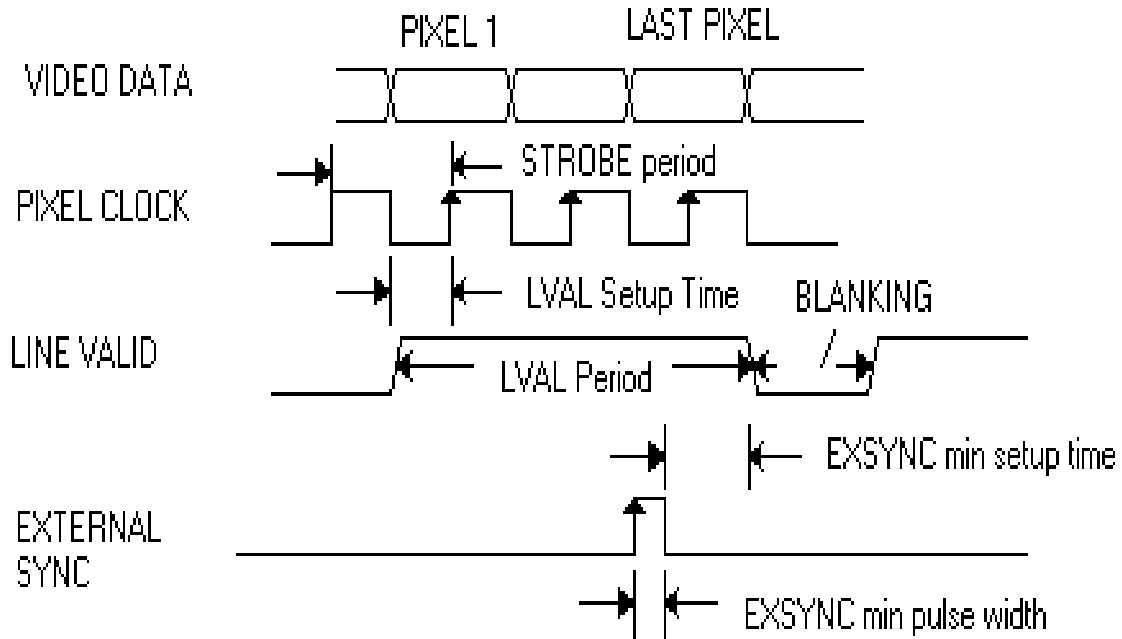

2K TDI LVDS	
Strobe period	:40 nS
LVAL set-up time	:20 nS
Line period (min.)	:21.8 uS
Blanking	:0.8 uS
ExSync min pulse width	:120 nS

4K TDI LVDS	
Strobe period	:40 nS
LVAL set-up time	:20 nS
Line period (min.)	:43.1 uS
Blanking	:2.15 uS
ExSync min pulse width	:120 nS

## 1.8 Thermal Considerations

The Osprey camera series has been thermally designed to separate the camera electronics from the image sensor.

The sensor temperature is thermally linked near the four M4 mounting holes on the face of the camera. Fairchild Imaging recommends mounting the camera using these holes to minimize sensor dark current artifacts.



Fairchild Imaging recommends that gain or offset corrections are completed after the camera has been turned on for at least 15 minutes. To do offset correction, cover the lens with your lens cap. Follow this by removing the lens cap to complete a gain calibration. Make sure that gain calibration is completed with a uniform light source, illuminating the camera Field-Of-View (FOV).



Avoid excess ambient temperatures around the camera.

## SECTION 2

### Camera Hardware Interface

#### 2.1 Installation Overview

Before you integrate your camera into your system you should first determine some basic operating parameters such as what resolution you need. Do you know the speed of the object that your camera will be inspecting? One additional point you want to keep in mind is your lighting requirement.

Some other major items that you should identify early on in developing your system is the source of your EXSYNC control signal (framegrabber, custom controller, shaft/web encoder, etc.). You should also know—in advance—your sensor resolution and magnification requirements.

We will use a simple example to reinforce what we just told you in the above. Let's say that you have the following system to set up: inspect a web 10cm wide, moving at 2m/s, and you want 100 $\mu$ m on the web to be represented by one pixel (13 $\mu$ m).

Number of Pixels Necessary	$\frac{\text{Total width of image}}{\text{Desired resolution}} = \frac{10 \text{ cm}}{100\mu\text{m per pixel}} = 1000 \text{ pixels}$
----------------------------	--

Magnification	$\frac{\text{Pixel size}}{\text{Desired resolution}} = \frac{13\mu\text{m}}{100\mu\text{m per pixel}} = 0.130$
---------------	--

EXSYNC	$\frac{\text{Web speed}}{\text{Desired resolution}} = \frac{2\text{m/s}}{100\mu\text{m}} = 20\text{KHz}$
--------	--

Shaft Encoder Circumference      You require one pulse for every 100 $\mu$ m of object travel. Assuming a shaft/web encoder = 0.10m producing 1000 pulses/rev., shaft circumference must be 1000 x 100 $\mu$ m = 100mm

Remember, TDI cameras require PRECISE synchronization with the object velocity! (See example images below.)

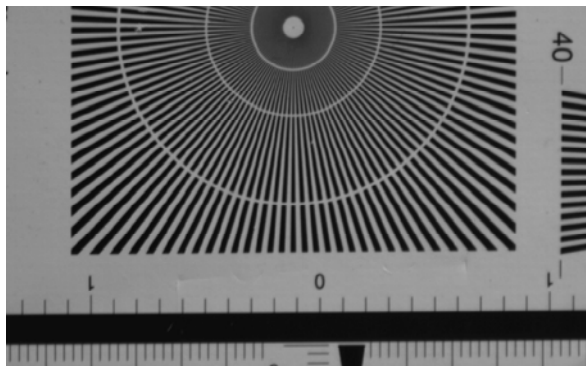

**Good TDI Synchronization**

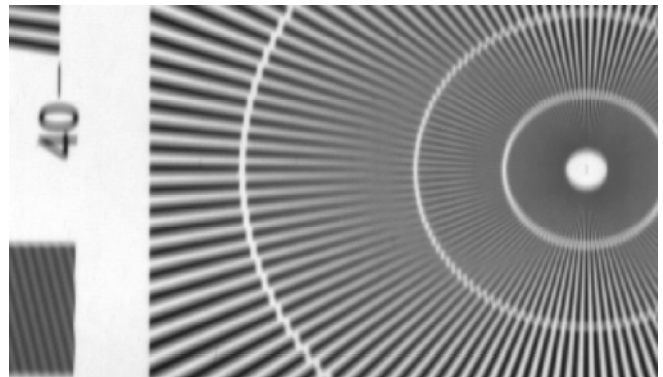

**Bad TDI Synchronization**

## 2.2 Connectors, Pinouts, and Cables

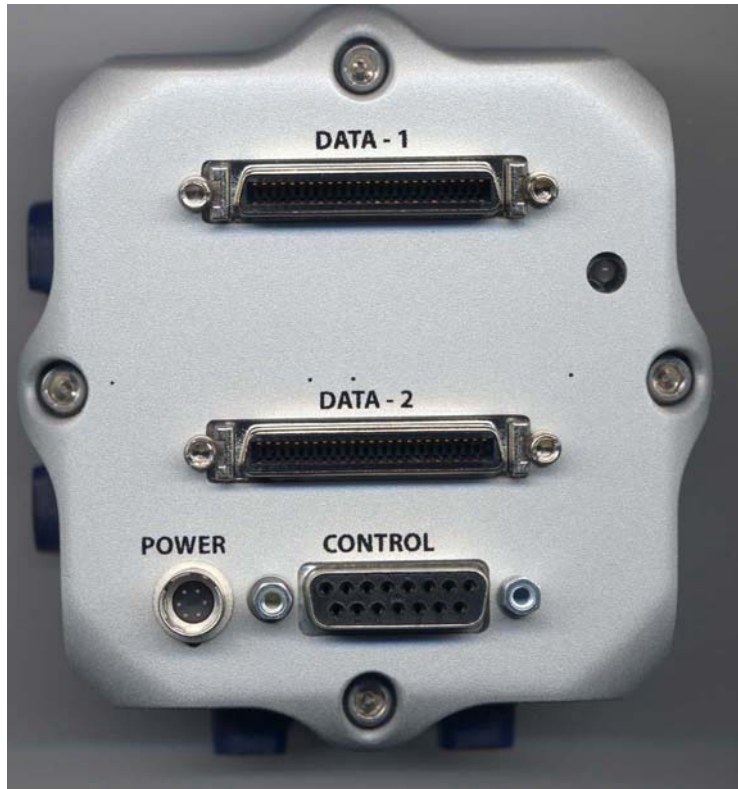

### 2.2.1 CONTROL-DB15 Connector, Amphenol Hood 17-1657-15 AMP Receptable 205205-2

Camera Pin #	Signal Name
12	+ExSync
4	-ExSync
5	+FrameSel
13	-FrameSel
14	+TDISEL0
6	-TDISEL0
8	+TDISEL1
7	-TDISEL1
10	SCLK
2	S Data In
9	SLOAD
11	RESETIN
1	S Data Out
15	GND



2.2.2 LVDS Data, DATA2 & DATA1 connector, 3M 10140-6000EC connector, 3M 10340-3210-000 hood or equivalent.

LVDS Data, DATA2 Camera Pin #	Signal Name	LVDS Data, DATA1 Camera Pin #	Signal Name
18	+D0	18	+D16
43	-D0	43	-D16
17	+D1	17	+D17
42	-D1	42	-D17
16	+D2	16	+D18
41	-D2	41	-D18
15	+D3	15	+D19
40	-D3	40	-D19
14	+D4	14	+D20
39	-D4	39	-D20
13	+D5	13	+D21
38	-D5	38	-D21
12	+D6	12	+D22
37	-D6	37	-D22
11	+D7	11	+D23
36	-D7	36	-D23
10	+D8	10	+D24
35	-D8	35	-D24
9	+D9	9	+D25
34	-D9	34	-D25
8	+D10	8	+D26
33	-D10	33	-D26
7	+D11	7	+D27
32	-D11	32	-D27
6	+D12	6	+D28
31	-D12	31	-D28
5	+D13	5	+D29
30	-D13	30	-D29
4	+D14	4	+D30
29	-D14	29	-D30
3	+D15	3	+D31
28	-D15	28	-D31
20	+FVAL	20	+LVALB
45	-FVAL	45	-LVALB
19	+STROBE	19	+STROBE
44	-STROBE	44	-STROBE
1-2	NC	1-2	NC
21-27	NC	21-22, 26-27, 46	NC
46-50	NC	23-25, 47-50	Reserved for JTAG programming

## 2.3 Power Supply

The camera uses a single voltage input, normally set to 12 volts @ 0.7 Amps typ., supplied through a Hirose connector. The supply must support a 850mA current surge for 100ms for proper camera operation.

Ripple and noise is required to be < 50 mV RMS for best camera noise performance.

Cable construction with shielded and grounded shields is required.

**Hirose HR25-7TR-6P Receptacle**

Pin #	Description
1	+12V
2	+12V
3	NC
4	GND
5	GND
6	NC

## 2.4 LED Indicator Status Lamp

The LED is bi-color to indicate the status of the camera operation. The LED color is **green** after initialization. If external SYNC is stopped or disconnected it will turn **RED**.

### Power Up: LED = **RED**

- Remains **RED** for approx. 0.1 second then turns to solid **green**.
- If the LED remains **RED** (or does not illuminate), the camera failed internal power up operation and should be returned to Fairchild Imaging for repair.

### Master Mode: LED = **GREEN**

- After power up with no EXSYNC input, the camera will default to “Master Mode” operation. The LVAL (line valid signal) (internally generated by the camera) will be at 23.191KHz line rate without any need for an external trigger.

### Slave Mode: LED = **GREEN**

- Once an EXSYNC signal is received the camera goes into a slave mode. The LVAL (line valid signal) period will track the SYNC input period. The line rate will vary according to the external trigger.
- The camera will remain in the slave mode until power is turned off (see Master Mode).
- If the EXSYNC (external trigger) is lost during “Slave Mode” operation, the LED will become **RED**. This indicates that the external trigger is interrupted and should be checked.
- Verify that the external trigger is not disabled.
- Verify that the control connector is connected and secured properly.

## SECTION 3

### Camera Control

#### 3.1 Quick Start with LVDS Interface

Follow your frame grabber manufacturer's instructions when inserting the frame grabber card into your PC. Be sure that you install the correct configuration software that matches the camera that you are using. Fairchild Imaging supplies configuration files for each camera type.

To enter into the realtime display, place your cursor in the window and hit return. At this point your camera should already be connected to the DC power supply and connected to the frame grabber in your PC. As soon as your camera starts communicating with the frame grabber, you can verify this fact by looking at your monitor and observing the video signal.

A quick word on LVDS: LVDS is short for Low Voltage Differential Signaling, a low noise, low power, low amplitude method for high-speed data transmission over copper wire.

LVDS differs from normal input/output (I/O) in a few ways. When a system uses LVDS technology, one of the big differences is a digital I/O works with 1.300V as a high = (binary 1) and 1.20V as a low = (binary 0).

Low voltage means that the standard 5 volts is replaced by a small differential signalling voltage. Additionally, LVDS uses a dual wire system, running 180 degrees opposed.

Standard TTL signaling: the data storage is based upon the actual voltage level compared against ground. The voltage level can be affected by wire length (longer wires increase resistance, which lowers voltage). LVDS data storage is distinguished only by positive and negative difference values, not the absolute voltage level. Therefore data can travel over greater lengths of wire while maintaining a clear and consistent data stream.

#### 3.2 Control Inputs

The Osprey family of cameras accepts user control signals through the DB15 connector on the back of the camera. Pin configuration is detailed in section 2.2.1.

##### EXSYNC – Triggers Line Readout

The 2K and 4K TDI cameras require EXSYNC for synchronization. The rising edge of EXSYNC triggers line transfer and line readout. EXSYNC must toggle from logic LOW to HIGH. If EXSYNC does not toggle from one state to the other, the camera will not output valid data. The minimum EXSYNC frequency for the Osprey cameras is 300 Hz.

One more word about EXSYNC: remember that the rising edge starts the line transfer and the falling edge must be a minimum of 100 nS after rising edge.

### 3.3 Providing External Triggering

There are two ways to provide external triggering to the 2K & 4K TDI LVDS cameras:

- Directly send the external trigger to the camera's DB15 control connector as mentioned earlier.
- Provide an external trigger to the frame grabber and it will send the EXSYNC signal to the camera.

#### 3.3.1 Direct Trigger

In this configuration, the EXSYNC is sent directly to the camera from the external LVDS trigger source (frame grabber, shaft encoder, etc.).

#### 3.3.2 LVDS Trigger Source

If the external trigger source is LVDS, it can be directly interfaced to the camera as illustrated below.

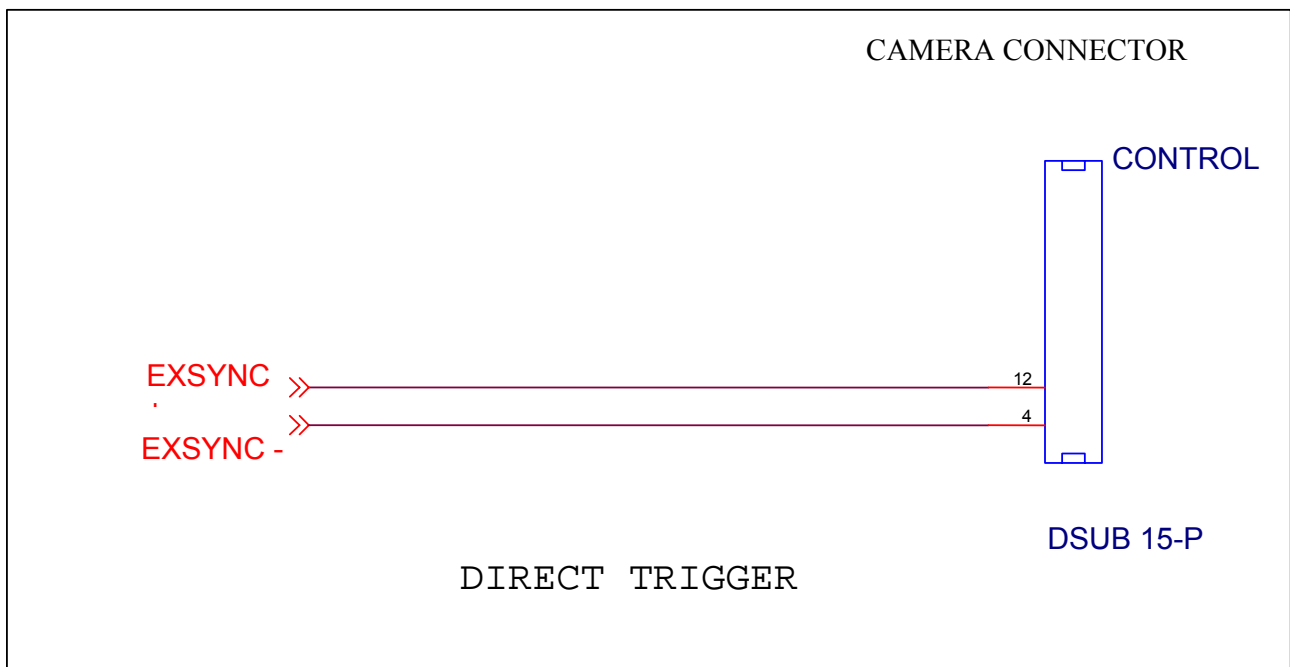

### 3.3.3 TTL Trigger Source

If the external trigger source is a TTL level, the signal needs to be converted to a LVDS signal before sending it to the camera. An example of this circuit is illustrated below:

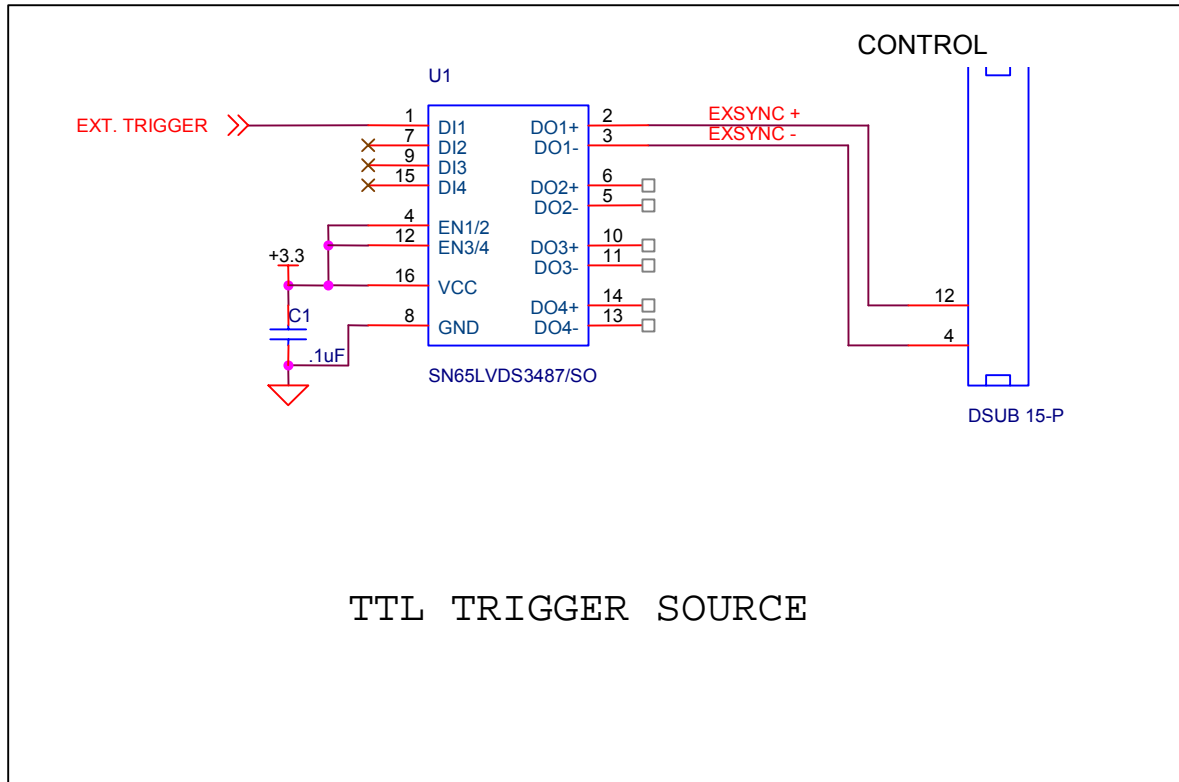

### 3.4 Frame Grabber Receives Trigger

When using the frame grabber to provide an EXSYNC to the camera, the frame grabber receives the external trigger source and it generates the EXSYNC. The EXTERNAL TRIGGER input signal will depend on what brand of frame grabber is used to interface to the camera. Consult the manufacturer's data sheet for the available types of signal level.

The following illustration shows the EXSYNC connection between the National Instrument's frame grabber and the camera control input DB15 connector. The frame grabber receives the TTL external trigger on pin 95 and generates an EXSYNC (LVDS level) on pins 33 and pin 34. This signal is then sent to the camera via twisted pair wires.

In order to have the frame grabber generate EXSYNC signal, some software programming using National Instrument's Labview application software is required.

This circuit is illustrated on the following page.

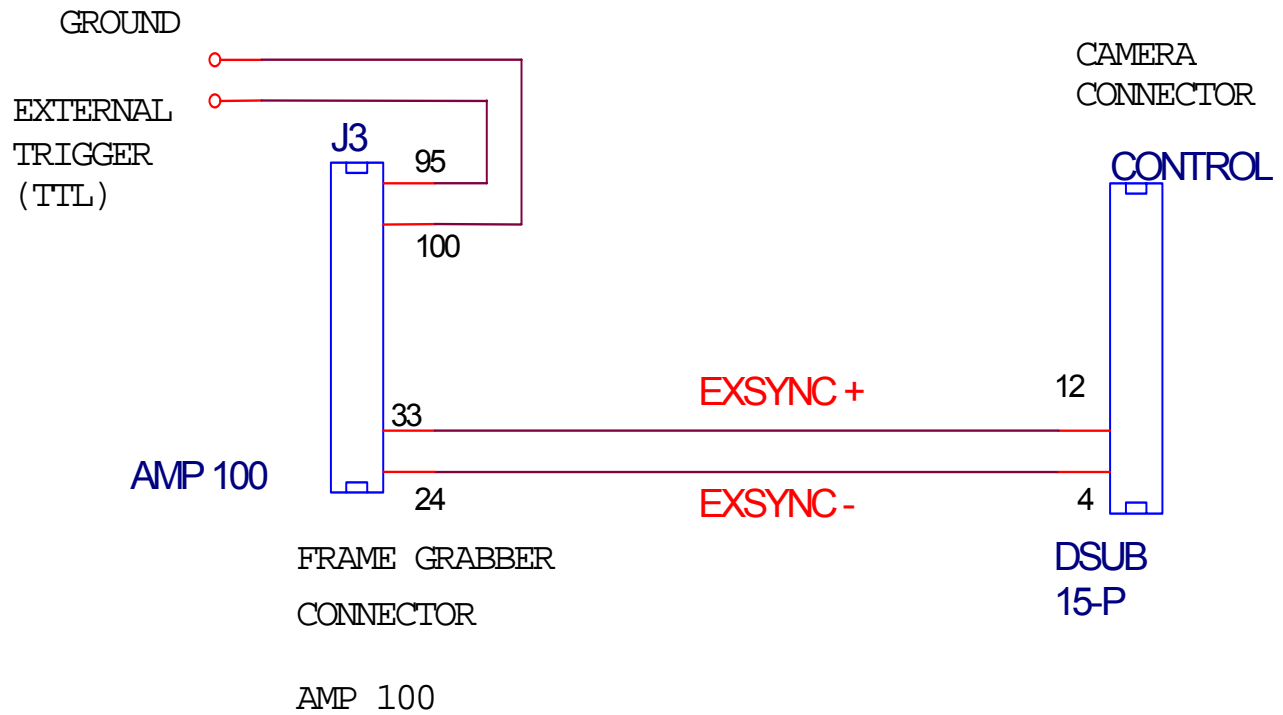

### 3.5 Frame Mode

Framing mode is an excellent tool for mechanical and optical aligning of the camera to the target. Frame mode is available in master mode only and the line rate is fixed at 23.19 KHz.

The circuit is shown on the following page.

An optional frame mode module is available from Fairchild Imaging.

## WIRING CONNECTION

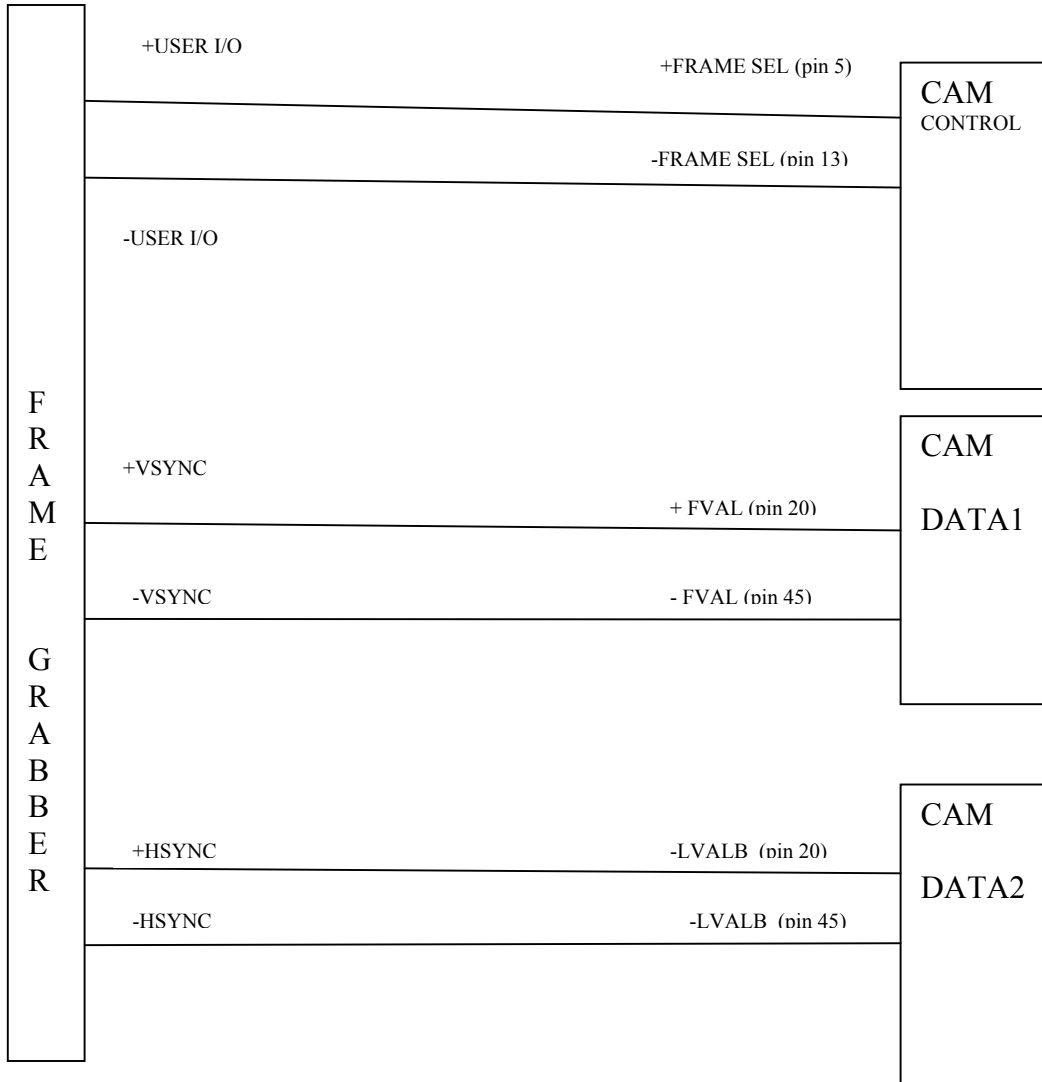

### 3.6 System Connection

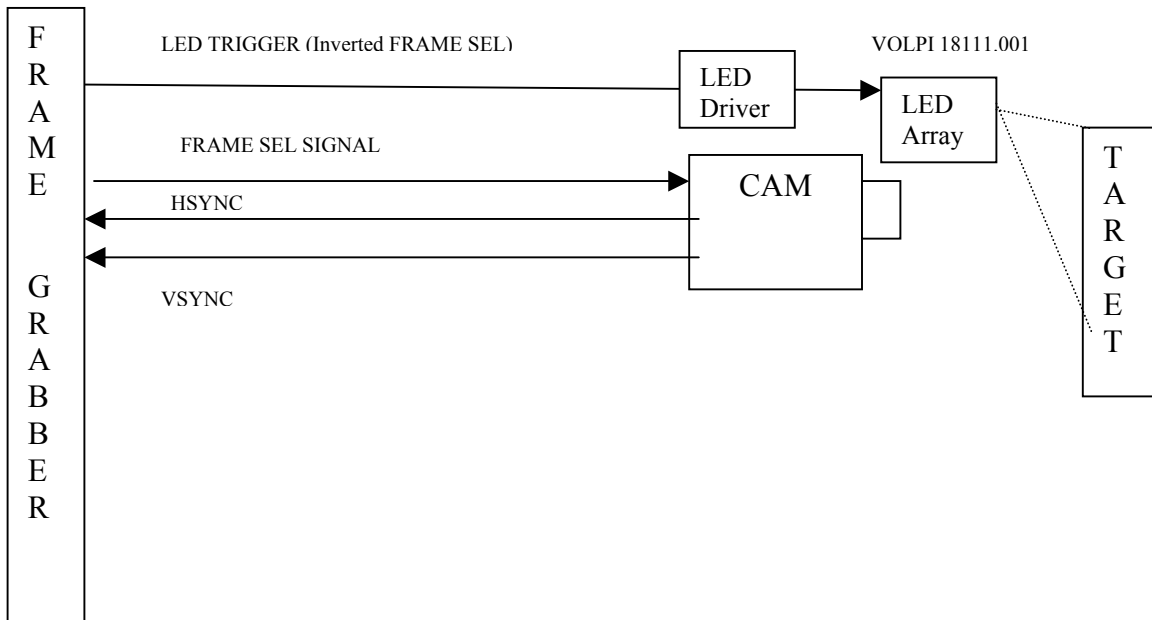

#### How to operate in framing mode

1. The camera must be running in master mode.
  - **External sync** signal cannot be present at power up.
2. Provide a LVDS active low "FRAME SEL" LVDS signal to pin 5 and pin 13 of the camera's control connector (DB15).

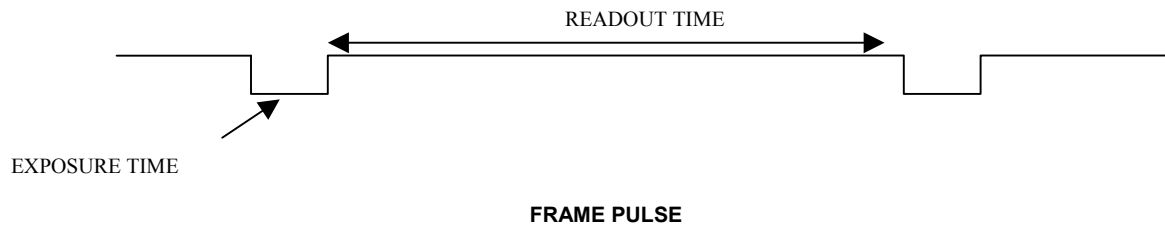

1. Provide the LED with a trigger pulse that is active high during the camera's exposure time.
  - An inverted FRAME SEL pulse with LED driver could be used. This requires a LVDS receiver that will convert the FRAME SEL signal to TTL. This signal will turn ON a transistor or a FET to drive the LED light source.
  - If a TTL signal is available from the frame grabber, this could directly drive the LED driver.

### 3.7 TDI Length Selection

TDI length selection for the 2K/4KTDI LVDS camera can be selected using the combination of TDISEL0 and TDISEL1 input signal into the DB15 control connector.

The TDISEL0 and TDISEL1 are LVDS level signals. They are typically wired to the user control I/O of the frame grabber.

For 4KTDI LVDS cameras, the TDI lengths are available for 96, 64, 32 and 16. They are programmed as follows:

<u>TDI LENGTH</u>	<u>TDISEL1</u>	<u>TDISEL0</u>
96	HIGH	HIGH (Default Setting)
64	HIGH	LOW
32	LOW	HIGH
16	LOW	LOW

HIGH = Logic 1  
LOW = Logic 0

For 2KTDI LVDS camera, the TDI lengths are available for 96, 64, 48 and 32. They are programmed as follows:

<u>TDI LENGTH</u>	<u>TDISEL1</u>	<u>TDISEL0</u>
96	HIGH	HIGH (Default Setting)
64	HIGH	LOW
48	LOW	HIGH
32	LOW	LOW

HIGH = Logic 1  
LOW = Logic 0

### 3.8 Gain and Offset Calibration

Gain and offset calibration are supported with use of the "FI LVDS Camera Control" graphic user interface (GUI).

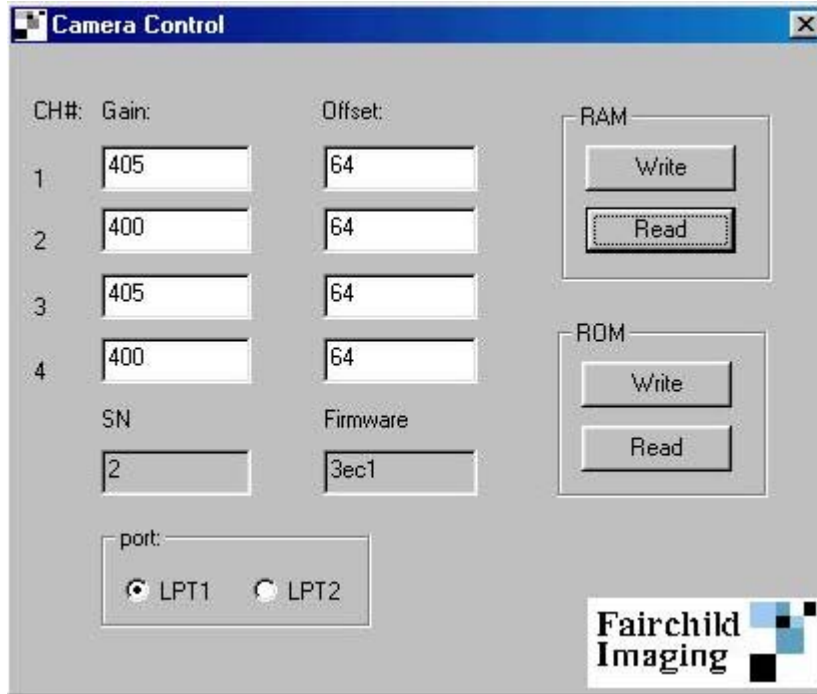

**Note:** When saving directly into ROM, stored values are not applied until after power cycle. Values written to RAM are implemented immediately.

### 3.9 How to Modify Gain & Offset Values

1. Read the data stored in the ROM and record the factory adjusted values.
2. Enter the gain changes for CH1 through CH4.
3. Write the changes to the RAM.
  - A typical value with optimal noise performance is 400
  - Recommended maximum values is 600 (maximum value is 1023)
4. Use a flat illumination source, inspect the gain balance between the four channels.
5. Repeat step 2 to 4 until all the channels are matched.
6. Enter the offset changes for CH1 through CH4 (with lens cap on).
7. Write the changes to the RAM.
  - A typical value is 64
8. With no illumination to the CCD (completely dark), inspect the offset balance between the four channels. (Fairchild Imaging nominal Dark Field Value is 4.0 DN.)
9. Repeat step 6 to 8 until all the channels are matched.
10. Select "WRITE" ROM. The data will be permanently stored in the EEPROM.
11. Power cycles the camera to apply stored values from the EEPROM.

## **3.10 Data Bus**

The 2K and 4K TDI cameras have 4 channels of 8-bit digital data in RS-644 (LVDS) format. See Reference B of this manual for detailed information on RS644. Both 2K and 4K TDI cameras output the clocking signals STROBE and LVAL.

### **3.10.1 STROBE**

STROBE is an internal pixel clock inside the camera (fixed at 25 MHz) data rate. To acquire valid data, frame grabbers usually latch to the rising edge of STROBE with LVAL high.

### **3.10.2 LVAL (Horizontal Synchronization)**

LVAL is a horizontal synchronization signal. When LVAL is in logic HIGH, the camera (2K or 4K TDI) will be outputting valid data.

### **3.10.3 FVAL (Frame Mode Synchronization)**

FVAL is an internally generated synchronization signal. When the camera is in master mode and triggered as shown in Section 3.6, FVAL will be high during the valid frame output period.

## SECTION 4

### Mechanical and Optical Considerations

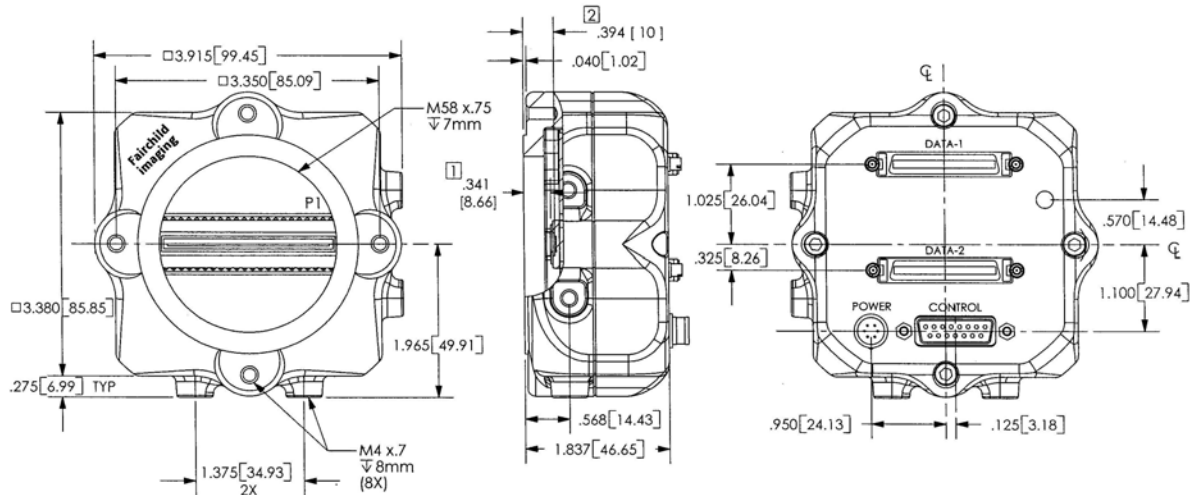

#### 4.1 Camera Dimensions and Mounting

The 2K and 4K TDI camera housings are manufactured with high precision. Sensor alignment is to the four M4 face mounting holes.

The 2K and 4K TDI camera housings are equipped with four M4 mounting holes on the front and two M4 mounting holes on one side and on the bottom of the camera.



Use caution in the following ways to avoid stripping threads or stressing the case:

- Use only M4 screws.
- Do not over torque; do not over tighten screws beyond the depth of the holes; do not otherwise force screws or create a bending moment with them.
- Use caution in crafting mounting brackets so that you do not interfere with the lens or exert force on the lens extender tube barrel, or torque or otherwise place force on any of the connectors on the back of the case. A "L" mounting bracket (section 4.3) is available; contact your Fairchild Imaging representative for more details.

## 4.2 Lenses

The 2K and 4K TDI cameras as shipped from the factory accept M58 optical components with M58 threads. The 4K TDI camera only accepts M58 lens types. A sample lens system for 256 DPI would include the following:

40mm lens, Schneider P/N 25-014798  
Focus Mount, Schneider P/N 21-013048  
Adapter, Schneider P/N 25-020054

When the lens mount (lens extender tube and its lock ring) is removed, the front surface of the camera is seen as a square with a large threaded hole in the center. The "z" distance from the surface of the square to the top of the sensor is 10.0mm. For the 256 DPI example above, the "Free and Clear" distance between the camera and object is 393mm.

### 4.3 Mechanical Drawing of Optional Camera Face Mounting "L" Bracket

Contact your Fairchild Imaging representative for more details.

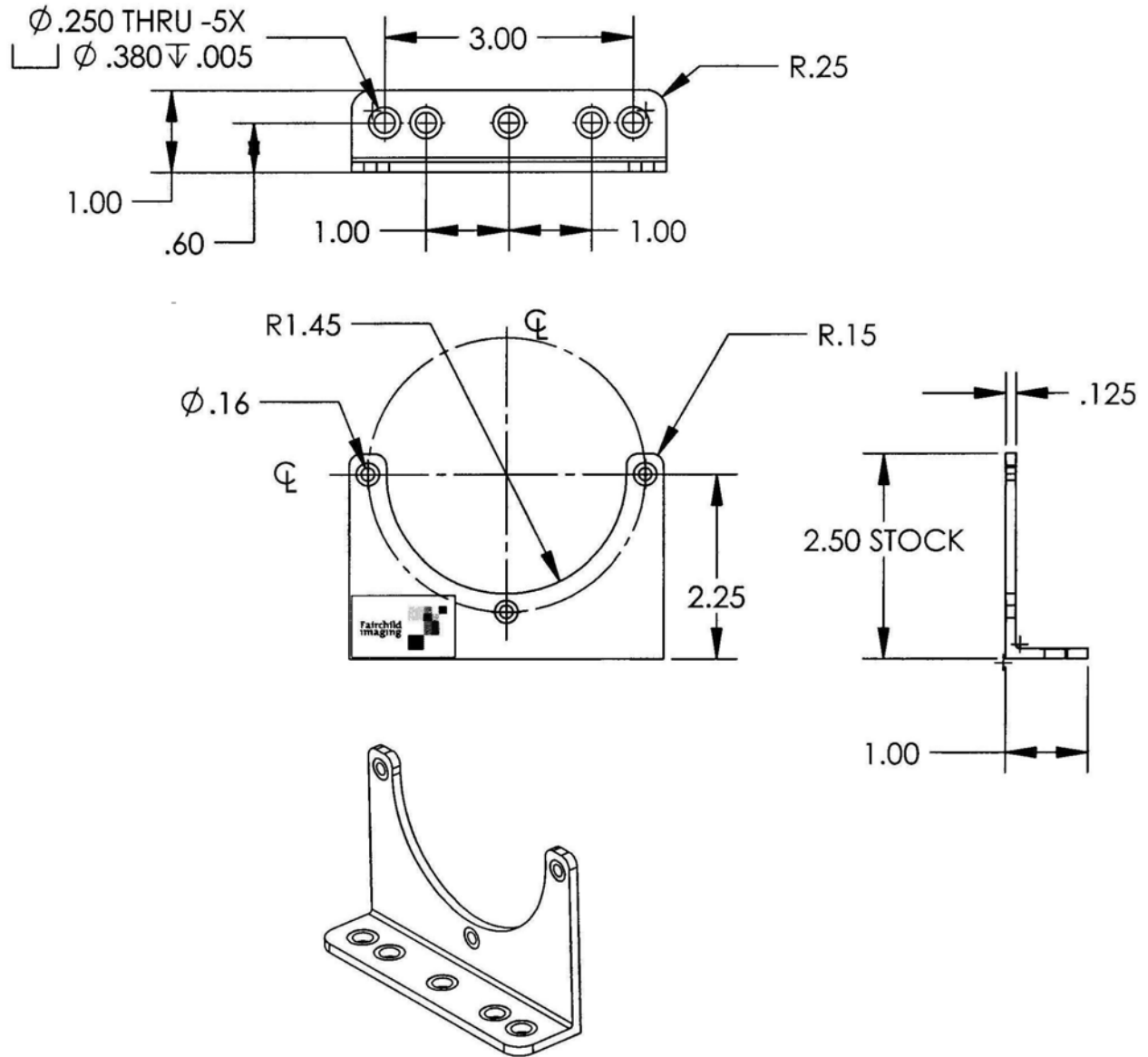

### 4.4 Lenses

Fairchild Imaging does not supply lenses. An example lens setup is detailed in Section 4.2 above.

## 4.5 Illumination

In your application you must know the amount and wavelengths of light required. Some additional things you want to consider respective to illumination are the characteristics of your light source and the spectral characteristics and speed of the object(s) being inspected.

## 4.6 Light Sources

When selecting and setting up your light source you should be aware of the following:

- Light sources do age over time.
- When light sources age, they may produce less/more light in some areas of the spectrum.
- Fairchild Imaging cameras work well with either tungsten or solid-state (LED) illumination sources. With tungsten sources, spectral shaping using a typical BG38 or IR-Cut filter is recommended.

## 4.7 Lens Modeling

Several camera companies have included this and like information in their manuals. For reference material it is very useful.

The **focal point** is the point at which the image of an infinitely distant object is brought to focus. The **effective focal length ( $f'$ )** is the distance from the second principal point to the second focal point. The **back focal length (BFL)** is the distance from the image side of the lens surface to the second focal point. **The object distance (OD)** is the distance from the first principal point to the object.

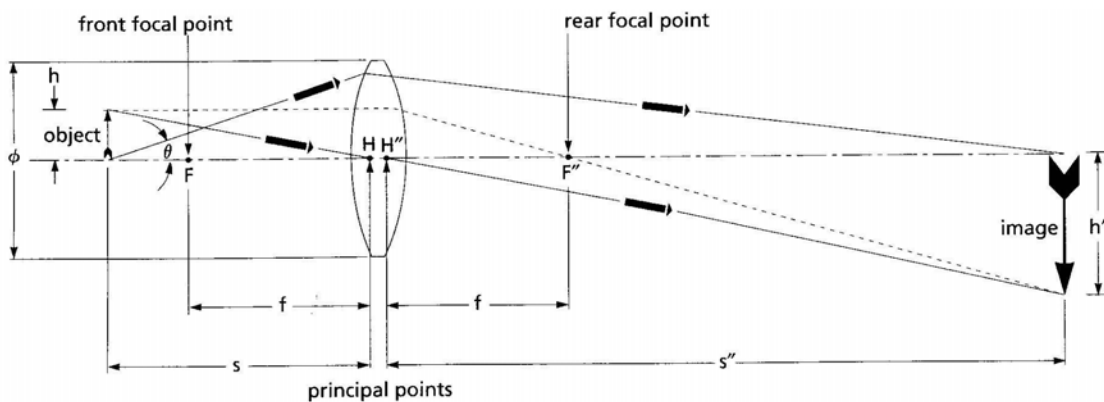

Note location of object and image relative to front and rear focal points.

## 4.8 2K and 4K LVDS Cable Harness

Our family of TDI cameras can be mated with the following framegrabbers:

National Instruments  
Coreco  
Matrox Meteor

Drawings that annotate the Bills of Materials, Assembly Instructions, and Wiring Diagram for each cable harness can be downloaded from our website [www.fairchildimaging.com](http://www.fairchildimaging.com).

When using one of the following framegrabbers in your system, you can select and download the appropriate cable harness drawing that will provide you information to build your cable harness.

<b>Framegrabber Model No.</b>	<b>Fairchild Imaging Cable Harness Part No.</b>
National Instruments PCI-1424	10499-3-02-1
Coreco PC-DIG LVDS	10499-3-02-2
Matrox Meteor 2 LVDS	10499-3-02-3

## SECTION 5

### Handling Instructions

#### 5.1 Electrostatic Discharge

The Fairchild Imaging Osprey camera uses TDI technology in a CCD base, and as all such devices, has some limited inherent susceptibility to electrostatic discharge (ESD).

All reasonable and customary design steps have been taken to provide ESD protection circuitry.

Electrostatic charge placed at the sensor could cause charging of the chip which in some situations might not be readily dissipated and minor impact on performance might be temporarily experienced. Therefore, do not insert your finger or any other object into the lens mount barrel.

#### 5.2 Preventing ESD Damage

Please be certain to ground yourself prior to handling the camera.

Ensure that your working environment is grounded, including conductive floor mats.

Do not touch the window of the imager.

#### 5.3 Protecting Against Dust, Oil and Scratches

Be certain to avoid dust buildup on the sensor window, where it could block the optical path.

By not touching the surface of the sensor, you avoid introducing oil and avoid scratching the sensor window. Again, you should not insert anything into the lens mount barrel.

#### 5.4 Cleaning the Sensor Window

Use only clean dry air to blow off particulate matter on the sensor window

If cleaning of the sensor window is required, use lens wiping cloth with a *small amount* of eyeglass cleaning fluid. *Do not use solvent as it may smear the sensor window.*

## SECTION 6

# Troubleshooting

## 6.1 Check Simple Things First

When troubleshooting, you want to start the process with the obvious components contained within your system:

- Computer system: hardware & software
- Is the frame grabber plugged into the correct slot on the mother board?
- Are all electrical connections secure?
- Check to make sure that your light source is fully functional
- Make sure that the pin configurations for all of your cables are correct
- Make sure you have selected the correct lens for your camera

## 6.2 Use the Camera Control Interface to Perform Checks

In the Camera Control GUI, to verify that the camera returns preset data. Typical Gain Values are  $\approx 400$  while typical offset values are  $\approx 64$ . Values such as 2047 indicate the camera is not communicating properly and the I/O cable connections (or wiring) is suspect.

## 6.3 Other Areas You Should Check

### Contact Customer Support

Before you call for support, be sure to make a note of the camera settings and the frame grabber settings you are using. You should also have saved captured live images. Customer Support will frequently request that you e-mail copies of these captured images. See Section 7.

### Connections

Double check the pin outs of your cable. Make sure that the connections to the back of the camera and to your PC are secure.

### Power Supply Voltage

Make sure and measure that you have 12.0 volts at the camera connector.

### Noisy Power Supply

Check your power supply voltage output(s). Check also the noise and ripple specification of your power supply and measure both at the power supply output.

## **Everything Seems to be Working, But No Image**

Remove the cover from your PC and reset all the cards into the mother board. Sometimes when you move your PC, cards inside the PC work themselves loose. Don't forget to check for optical path obscuration also.

## **Data Clocking/Output Signals**

Verify the presence of all data clocking and output signals at the connector pins on the camera housing. This is easily done by disconnecting the J7/J8 data cables and probing the connector pins with an oscilloscope. Remember, the camera will free-run at the maximum scan rate even with no frame grabber connected. This makes diagnosing connection problems quick and easy!

## **Horizontal Lines or Patterns in Output**

To eliminate this type of problem use a DC light source. Also verify that data cables and ground shields are in-place and connected. Inferior cables do result in degraded image transfer fidelity.

## **No Output or Non Specification Output**

If your camera has no output or is putting out an unspecified signal unknown to you, check the length of your cable. If it is unnecessarily too long and not shielded, your cable most likely is picking up radiated noise and is inputting the noise into your image acquisition system.

## **Vertical Patterns in Output**

Sometimes you might see patterns in your output. Most likely these are caused by dirt on your lens or possibly contaminants on the sensor window. Clean both to remove all contaminants. Some vertical patterns can also be caused by improperly wired or shielded data cables also.

## **Images Are Too Bright or Too Dark**

The causes to this problem should be obvious, but many times are overlooked. If your captured image is too dark or light, then experiment with the lens aperture. Sometimes if you lengthen or shorten the Line Rate Period (ExSync) time this will affect your image.

Don't forget to check your lighting!

## **Images Look Noisy**

There are several things that can cause this condition. Try increasing and decreasing pixel gain until you find the right setting. Look for an increase in dark current. If the ambient temp. increases this will cause noise in the image.

Look at your light source. Keep in mind that it is better on the side of too much light rather than too little. Excess light allows internal gain reduction in the camera which, in turn, improves camera dynamic range. Also, if your light source is AC instead of DC this will make the image look noisy. If the object you are inspecting has different surface textures it can produce an image that may look noisy.

### **Bits That Do Not Change Value**

If you see that data bits are not changing values, after you have changed them, then the first thing to check is that the camera is not saturated by preventing light from entering. Following that, the data cable should be checked for correct wiring and grounding. All Fairchild Imaging cameras are delivered after completing an extensive set of Quality Conformance Inspection steps. These checks include no stuck bits are present in the camera output.

## SECTION 7

### Product Support

If, after troubleshooting your camera, you are still having problems, collect the following data about your application and call Fairchild Imaging Customer Support.

**Note:** You may also want to photocopy this fax page for sending information to Fairchild Imaging @ 408-735-7352

<b>Your Name</b>	
<b>Company name</b>	
<b>Your phone number</b>	
<b>Your Fax number</b>	
<b>Product Model Number</b> (e.g. CAM4KLVDS))	
<b>Camera serial number</b>	
<b>Detailed description of problem encountered</b>	Please attach description with as much detail as appropriate

**When calling Fairchild Imaging, 1-800-325-6975, ask for Customer Support**

## REFERENCE A

### Providing External Trigger Using PCI-1424 Frame Grabber

1. Modify the frame grabber cable with the following connection:

Refer to the **NI PCI-1424 TO 4KTDI LVDS CABLE PIN CONFIGURATION**

- Disconnect the wires that are connected to pins 95 and 100 of connector 5 (SCSI 100)
- Use a 6 inch coax cable and connect a BNC connector (male) on one end
- Connect the other end of the coax cable ( center conductor) to pin 95 (external trigger 0) of connector 5 (SCSI 100)
- Connect the shield of the coax cable to pin 100 (ground) of connector 5 (SCSI 100)

2. Connect the external trigger TTL source to the BNC connector.

3. The external trigger function of the PCI-1424 frame grabbers requires National Instrument's Labview software and NI-IMAQ software to operate.

- Start the Labview application software
- Open the file "Ext Trigger\_Display\_With\_No\_Vision2.vi"



Ext

Trigger\_Display\_With\_No\_Vi...

- In IMAQ environment -> Device and Interface
  - Create IMAQ- PCI-1424: fairchild4K
  - Select: Fairchild CAM 4KTDI for Channel 0



IMAQ-WINDOW.tif

- Run continuous capture on the Labview application

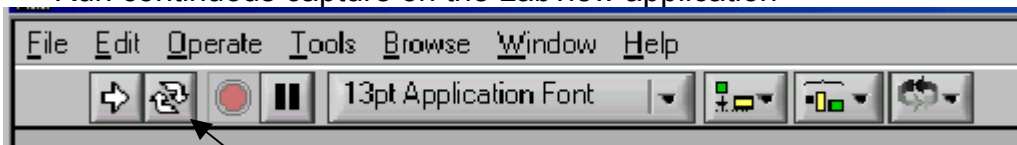

Continous Capture

## REFERENCE B

### Introduction to LVDS

National Semiconductor first introduced LVDS as a standard in 1994. National recognized that the demand for bandwidth was increasing at an exponential rate while users also desired low power dissipation. This exceeded the speed capabilities of RS-422 and RS-485 differential transmission standards. While Emitter Coupled Logic (ECL or PECL) was available at the time, it is incompatible with standard logic levels, uses negative power rails, and leads to high chip-power dissipation. These factors limited its wide spread acceptance.

LVDS is differential, using two signal lines to convey information. While sounding like a penalty, this is actually a benefit. The cost is two traces (or conductors) to convey a signal, but the gain is noise tolerance in the form of common-mode rejection.

Signal swing can be dropped to only a few hundred millivolts because the signal-to-noise rejection has been improved. The small swing enables faster data rates since the rise time is now so much shorter.

#### Getting Speed with Low Noise and Low Power

LVDS is a low swing, differential signaling technology, which allows single channel data transmission at hundreds or even thousands of Megabits per second (Mbps). Its low swing and current-mode driver outputs create low noise and provide very low power consumption across a wide range of frequencies.

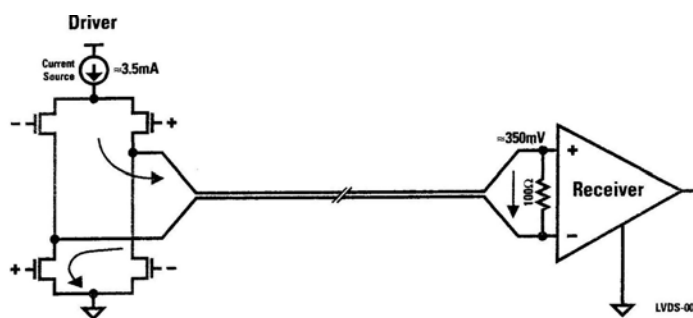

#### How LVDS Works

LVDS outputs consist of a current source (nominal 3.5 mA) that drives the differential pair lines. The basic receiver has a high DC input impedance so the majority of driver current flows across the  $100\Omega$  termination resistor generating about 350 mV across the receiver inputs. When the driver switches, it changes the direction of current flow across the resistor, thereby creating a valid "one" or "zero" logic state.

## The LVDS Standard

LVDS is currently standardized by the TIA/EIA (Telecommunications Industry Association/Electronic Industries Association) ANSI/TIA/EIA-644-A (LVDS) Standard.

The generic (multi-application) LVDS standard, ANSI/TIA/EIA-644-A, began in the TIA Data Transmission Interface committee TR30.2 in 1995. It was revised and published as ANSI/TIA/EIA-644-A in 2001. The ANSI/TIA/EIA standard defines driver output and receiver input characteristics, thus it is an electrical-only standard. It does not include functional specifications, protocols or even complete cable characteristics since these are application dependent. ANSI/TIA/EIA-644-A is intended to be referenced by other standards that specify the complete interface (i.e. connectors, protocol). This allows it to be easily adopted into many applications. To learn more about LVDS, visit National Semiconductor at [www.LVDS.national.com](http://www.LVDS.national.com).