

LM9637 Monochrome CMOS Image Sensor VGA 68 FPS

General Description

The LM9637 is a high performance, low power, 1/4" VGA CMOS Active Pixel Sensor capable of capturing monochrome still or motion images and converting them to a digital data stream.

Excellent image quality is achieved by integrating a high performance analog signal processor comprising of a high speed 10 bit A/D converter, fixed pattern noise elimination circuits and a programmable gain amplifier. The offset and black level can be automatically adjusted on chip using a full loop black level compensation circuit.

Furthermore, a programmable smart timing and control circuit allowing the user maximum flexibility in adjusting integration time, active window size, gain, frame rate. Various control, timing and power modes are also provided.

Features

- Master and slave mode operation
- Progressive scan read out with horizontal and vertical flip
- Programmable Exposure:
 - Master clock divider
 - Inter row delay
 - Inter frame delay
 - Partial frame integration
- Programmable gain amplifier
- Full automatic servo loop for black level & offset adjustment on each gain channel
- Horizontal & vertical sub-sampling (2:1 & 4:2) with averaging
- Windowing
- Programmable pixel clock, inter-frame and inter-line delays
- I²C compatible serial control interface
- Power on reset & power down mode

Applications

- Security Camera
- Machine Vision
- Barcode Scanners
- Biometrics

Key Specifications

Array Format	Total: 488 x 672 Active: 488 x 648
Effective Image Area	Total: 2.93mm x 4.03mm Active: 2.93mm x 3.89mm
Optical Format	1/4"
Pixel Size	6.0µm x 6.0µm
Video Outputs	8 & 10 Bit Digital
Frame Rate	68 frames per second
Dynamic Range	57 dB
Electronic Shutter	Rolling Reset
FPN	0.5%
PRMU	1.7%
Sensitivity	2.40 volts/lux.s
Fill Factor	49%
Micro Lens	none
Package	32 LCC
Single Supply	3.0V +/-10%
Power Consumption	130mW
Operating Temp	-10°C to 50°C

Overall Chip Block Diagram

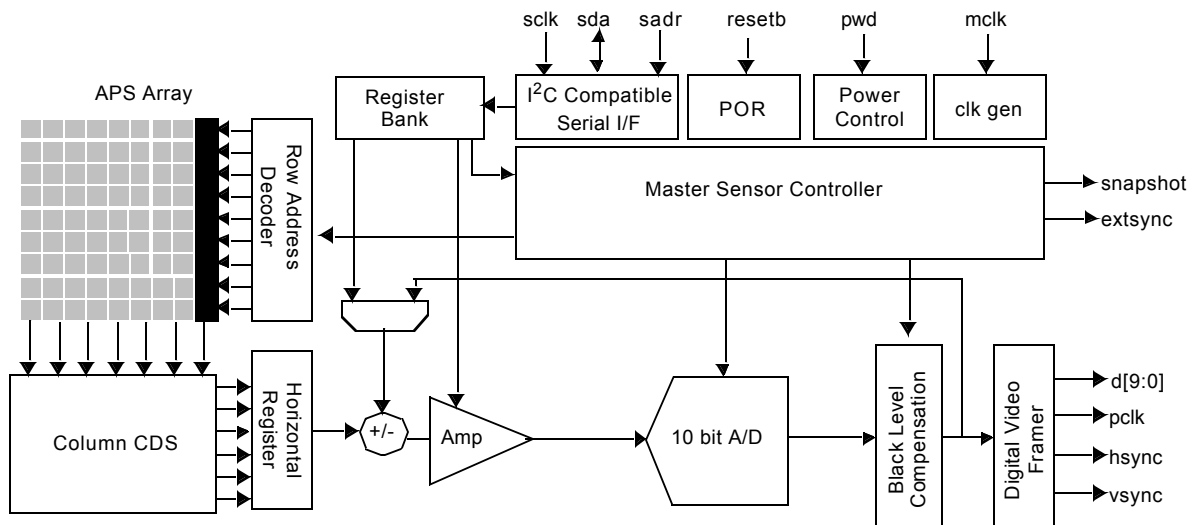

Figure 1. Chip Block Diagram

